



SUNPIER

GROUND MOUNT SYSTEM

PRODUCT INSTALLATION MANUAL



TABLE OF CONTENTS

2 – TABLE OF CONTENTS	11 – FIXED TILT INSTALLATION
2 – OVERVIEW	12 – SEASONAL ADJUSTABLE INSTALLATION
3 – UL 2703 CERTIFICATION	13 – Z-PURLIN INSTALLATION
3 – INSTALLER’S RESPONSIBILITY	14 – Z-PURLIN ASSEMBLY
4 – SAFETY INFORMATION	15 – MODULE INSTALLATION
5 – RECOMMENDED TOOLS	16 – DESIGN EXAMPLE
6 – SUNPIER COMPONENTS	17 – FAULT CURRENT PATH DIAGRAM
7 – DRIVEN PILE: I-BEAM	18 – ELECTRICAL SAFETY AND GUIDELINES
9 – DRIVEN PILE: C-CHANNEL	19 – UL2703 QUALIFIED MODULES
10 – POST SPACING	

OVERVIEW

The SunPier System is ideal for commercial solar installations where ground mounting is preferred for optimal solar exposure. Composed of only four main components, C-channel posts, trusses, support struts, and Z-purlins, this system is designed for efficient installation and optimal performance.

The SunPier System stands out due to its flexible installation options. It can be configured as a fixed tilt system, offering angles between 5° and 35°. In addition, it provides the option for seasonal adjustments, allowing angles to be modified from 15° to 60°, ensuring peak solar efficiency throughout the year.

The SunPier is UL 2703 certified for safety and durability, and it’s backed by a 25-year warranty. Our U.S. manufacturing partners can deliver projects under 3MW in as little as 7 days.



UL2703 CERTIFICATION

SunModo's SunPier System can be used to mount photovoltaic (PV) modules onto a wide variety of low sloped terrains. These installation instructions are of a general nature for installing the SunPier Ground Mount System. All installations shall be in accordance with NEC requirements in the USA. The SunPier System is for use with PV modules that have a maximum series fuse rating of 20A.

Mechanical design loads per UL 2703: Downward Pressure: 33.42 psf (1600.2 Pa), Upward Pressure: 22.28 psf (1066.8 Pa), Down-Slope: 5 psf (239.4 Pa).

The SunPier System is tested and recognized to UL 2703 standards for safety grounding and bonding equipment and meets UL 1703 fire standards.

INSTALLER'S RESPONSIBILITY

- Installer shall employ only SunModo products detailed herein. The use of non SunModo components can cancel the letters of UL compliance and product warranties.
- Installer is responsible to determine that the terrain and other structural components can sustain the array under all environmental loading conditions per the codes and standards; consult with a licensed professional engineer.
- Installer shall guarantee that screws have adequate pullout strength and shear capacities.
- Installer shall adhere to the torque values specified in this Instruction Manual.
- Installer shall adhere to all relevant local or national building codes. If any details of these installation instructions conflict with code requirements, installer should consult with SunModo.
- Installer shall guarantee the safe placement of all electrical details of the PV array.
- Installer to follow all applicable safety requirements during installation.
- Installer shall ensure bare copper grounding wire does not contact aluminum and steel components to prevent risk of galvanic corrosion.
- Installer is responsible for and shall provide an appropriate method of direct-to-earth grounding according to the latest edition of the National Electrical Code, including NEC 250: Grounding and Bonding, NEC 690: Solar Photovoltaic Systems.
- Installer shall comply with all applicable local, state and national building codes, including periodic re-inspection of the installation for loose components, loose fasteners, and any corrosion. If loose components or loose fasteners are found during periodic inspection, re-tighten immediately. If corrosion is found, replace affected components immediately.
- It is recommended that anti-seize lubricant be applied to the screw threads.

SAFETY INFORMATION



IMPORTANT

It is highly recommended that system installation and any subsequent modifications, disassembly, or reassembly be conducted by a factory authorized representative. Contact SunModo for additional information.



CAUTION: WATCH FOR WIRES!

Extreme caution should be taken when installing near power lines. For your own personal protection, the following safety steps should be taken:

- Perform as many functions as possible on the ground.
- Watch out for overhead power lines. Check the distance to the power lines before starting installation.
- Recommended minimum distance of 6 meters (20 feet) from all power lines.
- Do not use metal ladders.
- Do not install assembly on a windy day.
- If assembly slips, move away from it and let it fall.
- If any part of the assembly comes in contact with a power line, call your local power company. **DO NOT TRY TO REMOVE IT YOURSELF!** They will remove it safely.
- Make sure that the assembly is properly grounded.



WARNING

Assembling on windy days can be dangerous. Additional precautions should be taken when assembling in high wind areas. The modules surface, even in slight winds, create strong forces. Be prepared to safely handle these forces at unexpected moments. Do not attempt to assemble, move or mount assembly on windy days or serious, even fatal accidents may occur. SunModo is not responsible or liable for damage or injury resulting from antenna installations.



WARNING

Units improperly installed or installed to an inadequate structure can be susceptible to wind damage. This damage can be very serious and even life threatening. The owner and installer assumes full responsibility that the installation is structurally sound to support all loads (weight, wind and ice) and properly sealed against leaks. SunModo will not accept liability for any damage caused due to the many unknown variable applications.

RECOMMENDED TOOLS



1/2", 3/4" and 15/16"
Impact Sockets



Impact Driver



1/2", 3/4" and 15/16"
Spanner Wrench Set



Adjustable Torque Wrench



Magnetic Level



Line Level



Self-Leveling Laser Kit with Receiver



Tape Measure



Mason's Line



Anti-seize Lubricant
(Permatex 80071 or equivalent)

SAFETY: All applicable OSHA safety guidelines should be observed when working on a PV installation job site. The installation and handling of PV solar modules, electrical installation and PV racking systems involves handling components with potentially sharp metal edges. Rules regarding the use of gloves and other personal protective equipment should be observed.

SUNPIER COMPONENTS

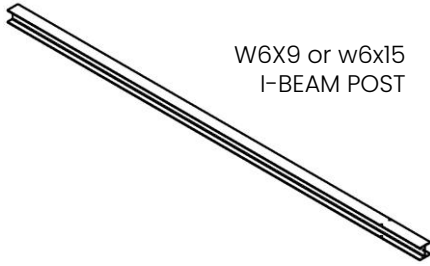

W6X9 or w6x15
I-BEAM POST

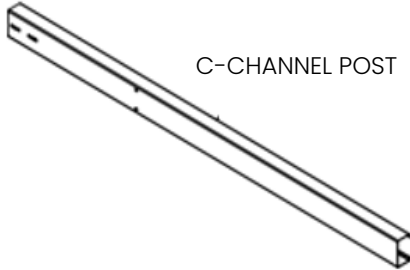

C-CHANNEL POST

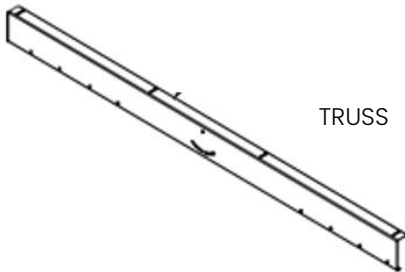

TRUSS

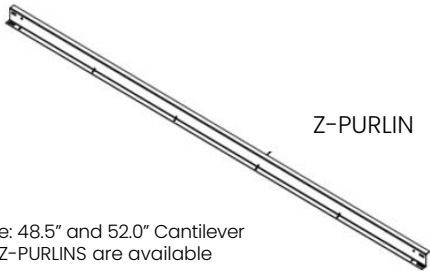

Z-PURLIN

Note: 48.5" and 52.0" Cantilever
Z-PURLINS are available

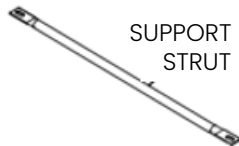

SUPPORT
STRUT



STRONGBACK
(Where Required)

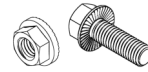

5/16" SERRATED FLANGE NUT &
5/16"-18 X 3/4" SERRATED FLANGE BOLT
MODULE HARDWARE

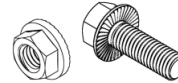

1/2" SERRATED FLANGE NUT &
1/2"-13 X 1-1/2" SERRATED FLANGE BOLT

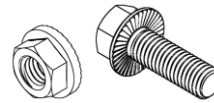

5/8" SERRATED FLANGE NUT &
5/8"-11 X 1-3/4" SERRATED FLANGE BOLT

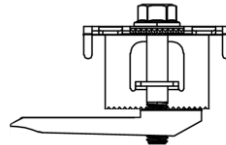

END CLAMP
ASSEMBLY

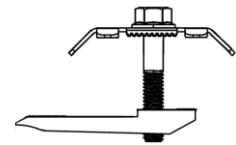

MID CLAMP
ASSEMBLY

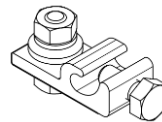

WEEB-LUG-6.7

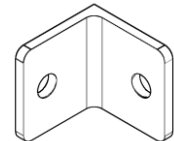

I-BEAM
CONNECTION TAB

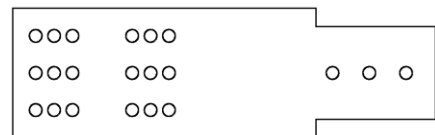

I-BEAM ADAPTOR PLATE

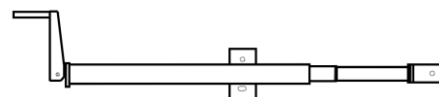

SEASON ADJUSTABLE JACK

DRIVEN PILE: I-BEAM

I-BEAM POST Install

Choose a site that is as level as possible; ideally terrain with a slope of +/- 5-degrees East-West. Install depth will be determined by many factors, such as region and local building code and national ASCE requirements.

NOTES:

- Consult a licensed Professional Engineer to determine optional anchoring requirements.
- W6x9 Posts are typically used when the desired module leading edge is up to 3.0 feet, depending on tilt angle and loads. The average embedment depth for the W6x9 I-Beam is between 7.0 feet and 9.0 feet.
- W6x15 Posts are typically used when the desired module leading edge is up to 8.0 feet, depending on tilt angle and loads. The average embedment depth for the W6x15 I-Beam is between 8.0 feet to 11.0 feet.

I-BEAM to ADAPTOR PLATE Assembly

Install 3X 5/8"-11 x 1-1/2" NUTS & BOLTS into the I-BEAM and ADAPTOR PLATE. Use a 15/16" hex socket and torque to 112 ft-lbs.

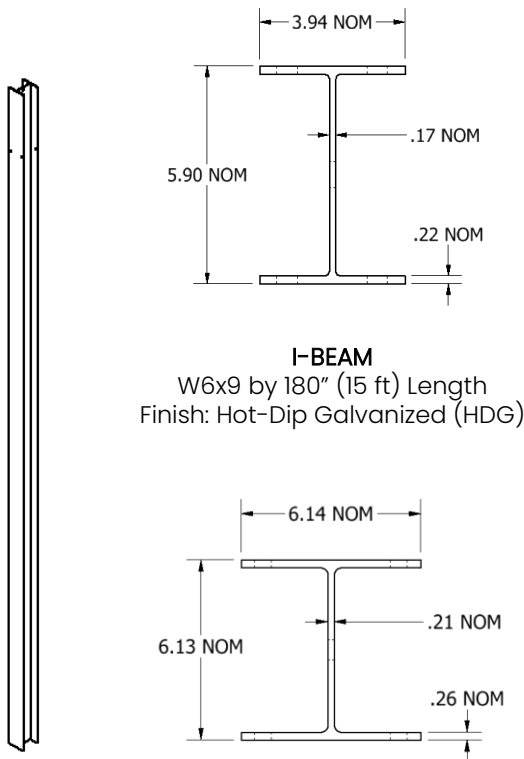

I-BEAM
W6x9 by 180" (15 ft) Length
Finish: Hot-Dip Galvanized (HDG)

I-BEAM
W6x15 by 240" (20 ft) Length
Finish: Hot-Dip Galvanized (HDG)

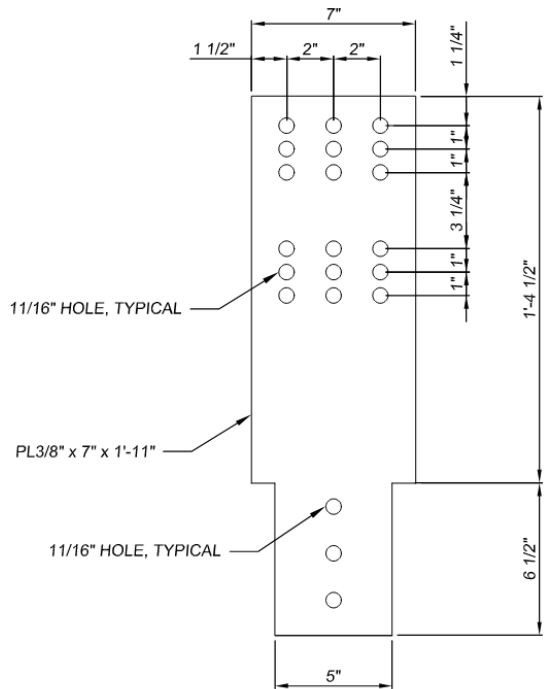

I-BEAM ADAPTOR PLATE
3/8" Thick Steel Plate
Finish: Hot-Dip Galvanized (HDG)

DRIVEN PILE: I-BEAM

ADAPTOR PLATE to TRUSS

Determine the desired TRUSS angle and install 2X 5/8"-11 x 1-1/2" NUT & BOLT into center/middle hole locations of the I-BEAM ADAPTOR PLATE. Use a 15/16" hex socket and torque to 112 ft-lbs.

- Note:
- The Upper and Lower holes in the ADAPTOR PLATE may be used for vertical adjustment.
 - The North and South holes may be used for North/South adjustment.

I-BEAM CONNECTION TAB to SUPPORT STRUT

Attached the CONNECTION TAB to the STRUT with 1x 1/2"-13 x 1-1/2" NUT & BOLT. Use a 3/4" hex socket and torque to 57 ft-lbs.

SUPPORT STRUT to I-Beam & TRUSS

Install the STRUT to the I-BEAM and TRUSS with 2x 1/2"-13 x 1-1/2" NUTS & BOLTS. Use a 3/4" hex socket and torque to 57 ft-lbs.

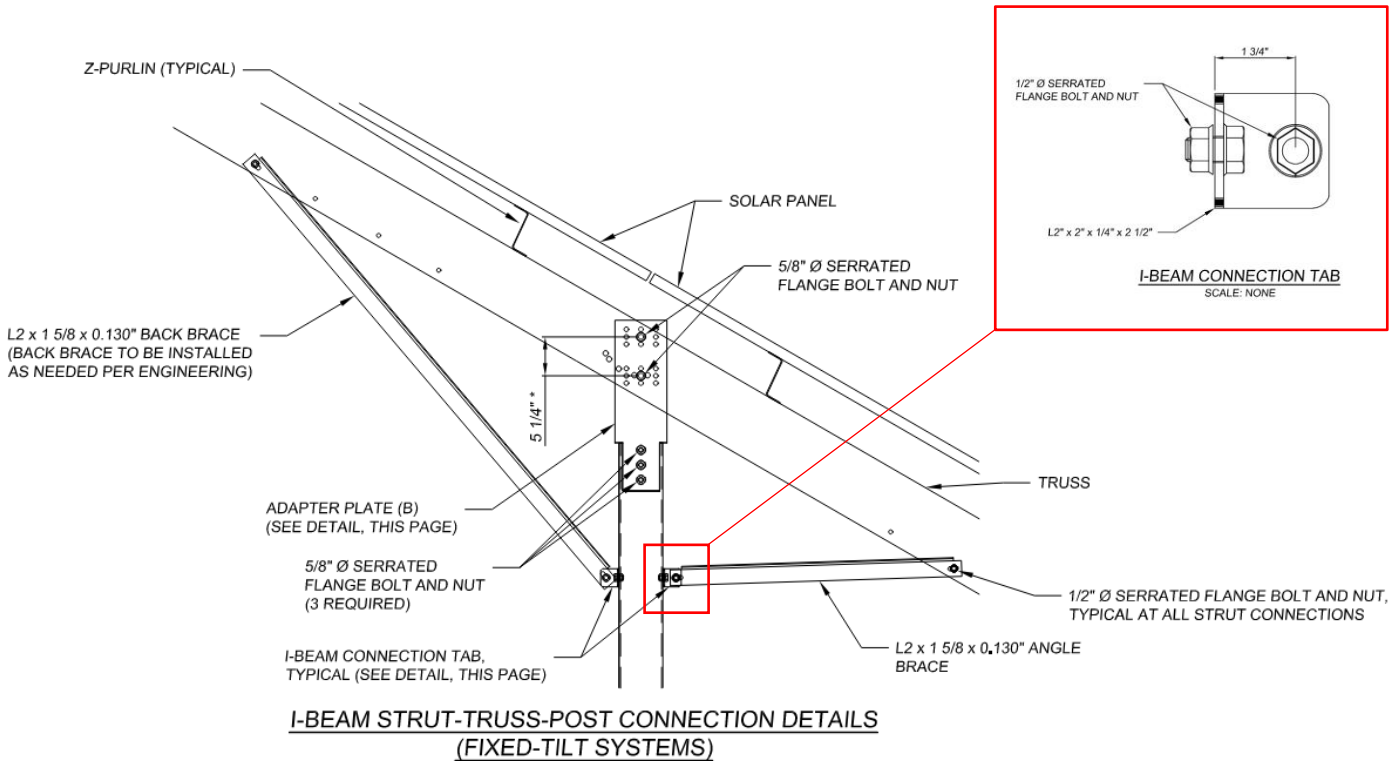

DRIVEN PILE: C-CHANNEL

C-CHANNEL POST Install

Choose a site that is as level as possible; ideally terrain with a slope of +/- 5-degrees East-West. Install depth will be determined by many factors, such as region and local building code and national ASCE requirements.

NOTE: Consult a licensed Professional Engineer to determine optional anchoring requirements.

- Post Driven: Average embedment depth = 6.5 feet to 8.5 feet.
- Concrete Footer: Average is 24-inch OD x 6.0 feet to 7.0 feet deep.
- Concrete Ballast Block: Typical size 120-inch L x 30-inch W x 12-inch H.

NOTE: EVEN tilt angles (20 and 30-degrees) are achieved when the flat side of POST faces East. And ODD tilt angles (5, 25, and 35-degrees) are achieved when flat side of POST faces West.

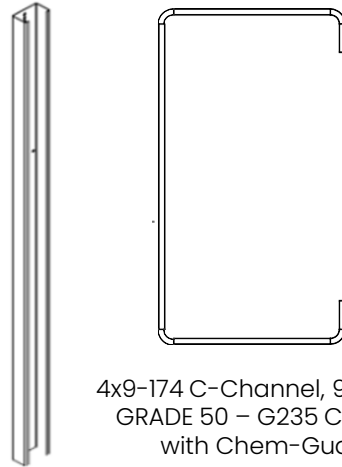

Fixed Tilt Systems:

EVEN tilt angles (20 and 30-degrees) are achieved when the flat side of POST faces East.

ODD tilt angles (5, 25, and 35-degrees) are achieved when flat side of POST faces West.

Season Adjustable Systems:

Flat side of POST faces West allowing angles to be modified from 15° to 60°

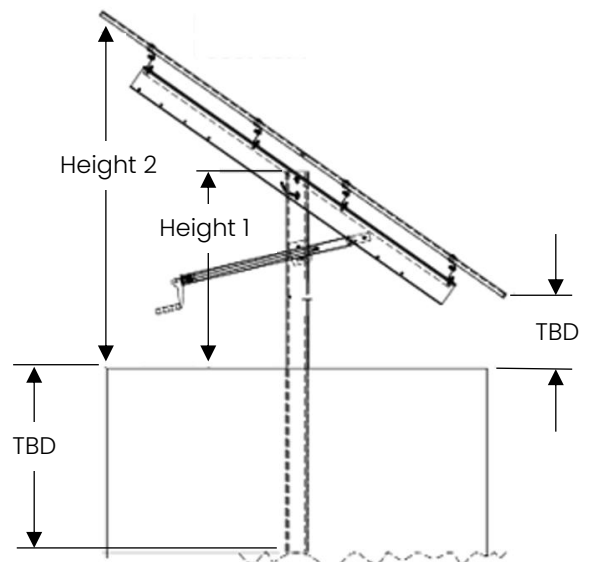
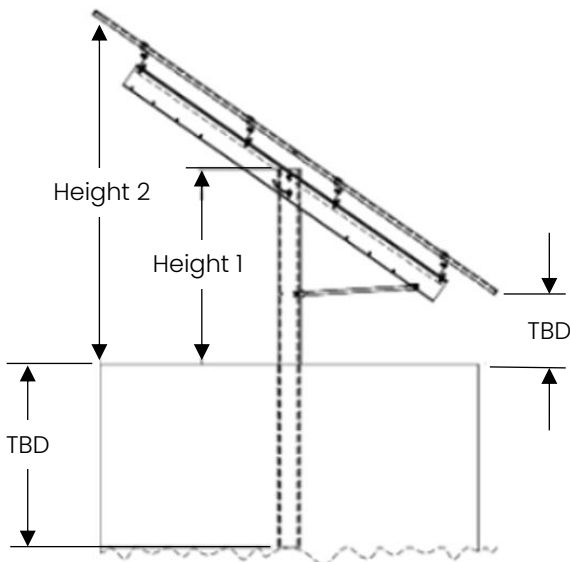

POST SPACING

DRIVEN PILE POST Spacing

It is advised to construct the system from East to West, as this method allows for a more effective progressive overlapping of the Z-PURLINS one on top another.

POST spacing dimensions for 214" Z-PURLINS used with module frames 40 to 42-inches wide:

- 160-inch Center to Center spacing for East start section.
- 212-inch Center to Center spacing (West 10x Panel Add Section).
- 153-inch Center to Center spacing (West 8x Panel Add Section).
- 111-inch Center to Center spacing (West 6x Panel Add Section).

POST spacing dimensions for 186" Z-PURLINS used with module frames greater than 43-inches wide:

- 160-inch Center to Center spacing for East Start Section.
- 184-inch Center to Center spacing (West 8x Panel Add Section).
- 104-inch Center to Center spacing (West 6x Panel Add Section).

Note: Use the 5/16"-18 MODULE HARDWARE to secure Large Format Modules to the Z-PURLINS. Use a 1/2" hex socket and torque to 12 ft-lbs.

CANTILEVER EXTENSIONS

Four additional modules, one column on either side, can be added using CANTILEVER EXTENSIONS on the East & West ends of the arrays.

NOTE: Overlap the CANTILEVER Z-PURLINS (48.5" or 52.0") by 6-inches and secure using 4x 1/2"-13 x 1-1/2" NUTS & BOLTS. Use a 3/4" hex socket and torque to 57 ft-lbs.

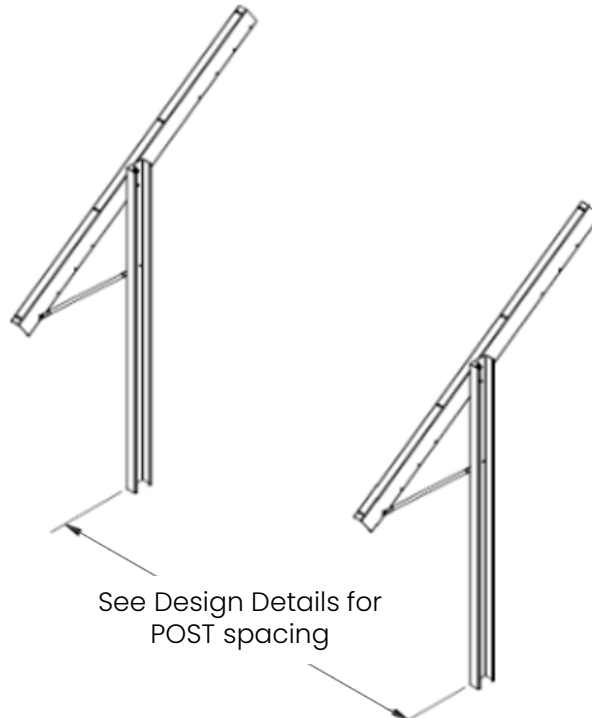

FIXED TILT INSTALLATION

TRUSS to C-CHANNEL POST

Fasten the TRUSS to the C-CHANNEL POST at the desired angle using the hardware provided. Then attach the SUPPORT STRUT to the TRUSS and POST using additional hardware.

NOTE: The C-CHANNEL POST has a 18x hole pattern for +/- 1.0-inch tolerance up & down and 1-1/2" tolerance North & South.

NOTE: EVEN tilt angles (20 and 30-degrees) are achieved when the flat side of POST faces East. And ODD tilt angles (5, 25, and 35-degrees) are achieved when flat side of POST faces West.

TRUSS to C-CHANNEL POST

Install TRUSS to the POST with 2x 5/8"-11 x 1-1/2" NUTS & BOLTS. Use a 15/16" hex socket and torque to 112 ft-lbs.

SUPPORT STRUT to C-CHANNEL POST & TRUSS

Install STRUT to the POST and TRUSS with 2x 1/2"-13 x 1-1/2" NUTS & BOLTS. Use a 3/4" hex socket and torque to 57 ft-lbs.

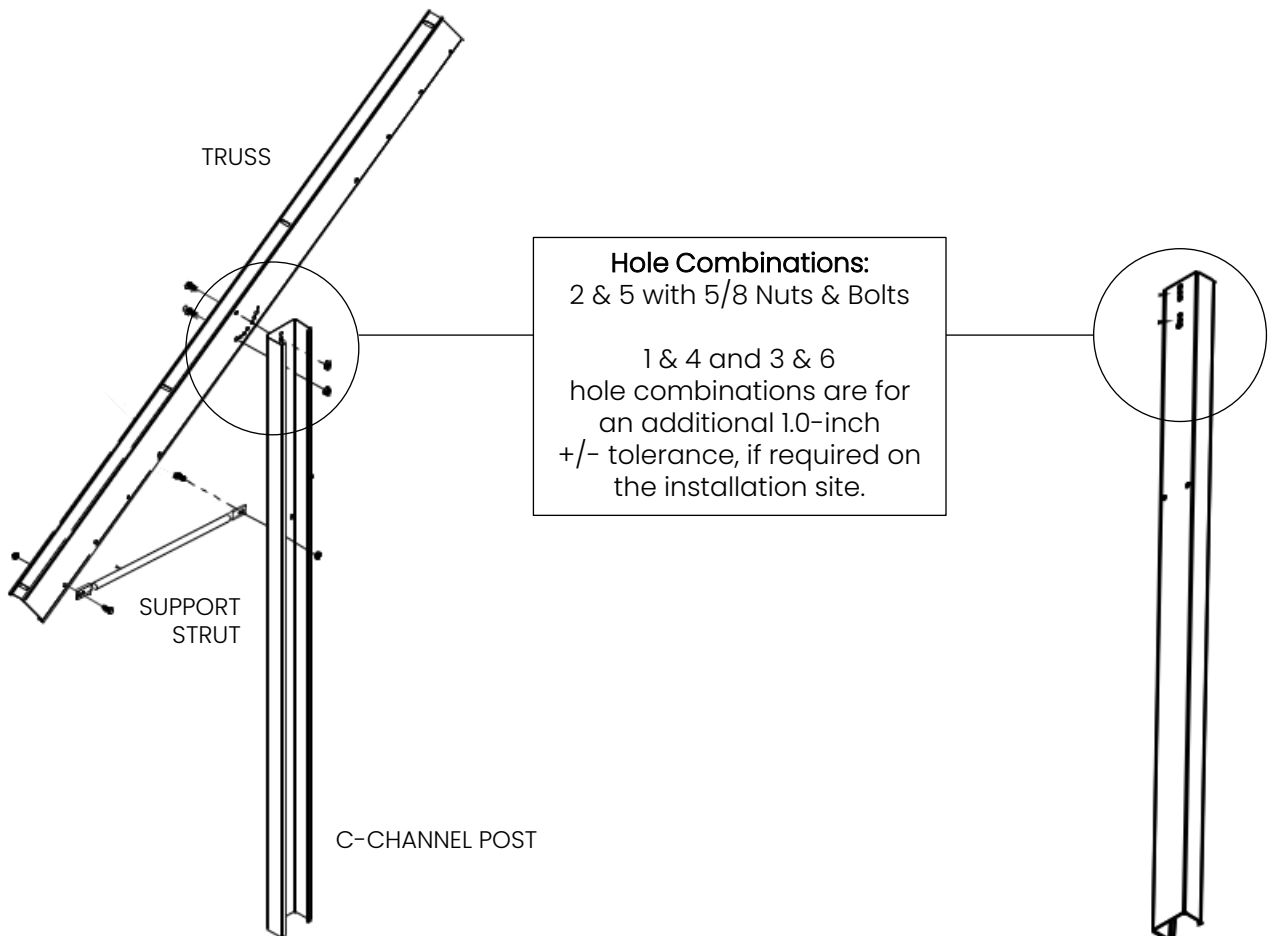

SEASON ADJUSTABLE INSTALLATION

TRUSS to C-CHANNEL POST Assembly

Fasten the TRUSS to the C-CHANNEL POST using the hardware provided. Then attach the SEASON ADJUSTABLE JACK to the TRUSS and POST using additional hardware.

NOTE: The C-CHANNEL POST has a 18x hole pattern for ± 1.0 -inch tolerance up & down and $1\frac{1}{2}$ " tolerance North & South.

TRUSS to C-CHANNEL POST

Install the TRUSS to the POST with 1x $5\frac{1}{8}$ "-11 x $1\frac{1}{2}$ " NUT & BOLT. Use a $15\frac{1}{16}$ " hex socket and torque to 112 ft-lbs. After BOLT installation the NUT should be loosened $\frac{1}{2}$ -turn and a second NUT installed with the serrated flange facing away from the first NUT.

SEASON ADJUSTABLE JACK to C-CHANNEL POST & TRUSS

Install the JACK by hand tightening the hardware, backing off the NUT $\frac{1}{2}$ -turn, and adding a second nut at each location. This will allow the JACK to pivot freely, while also preventing further movement of the hardware.

Secure the JACK to the POST and TRUSS with 3x $1\frac{1}{2}$ "-13 x $1\frac{1}{2}$ " BOLTS and 6x $1\frac{1}{2}$ "-13 NUTS. Use a $\frac{3}{4}$ " hex socket and torque to 57 ft-lbs.

NOTE: When seasonal adjustments are made, adjust the JACK on each POST in 5-degree increments to avoid damaging the array.

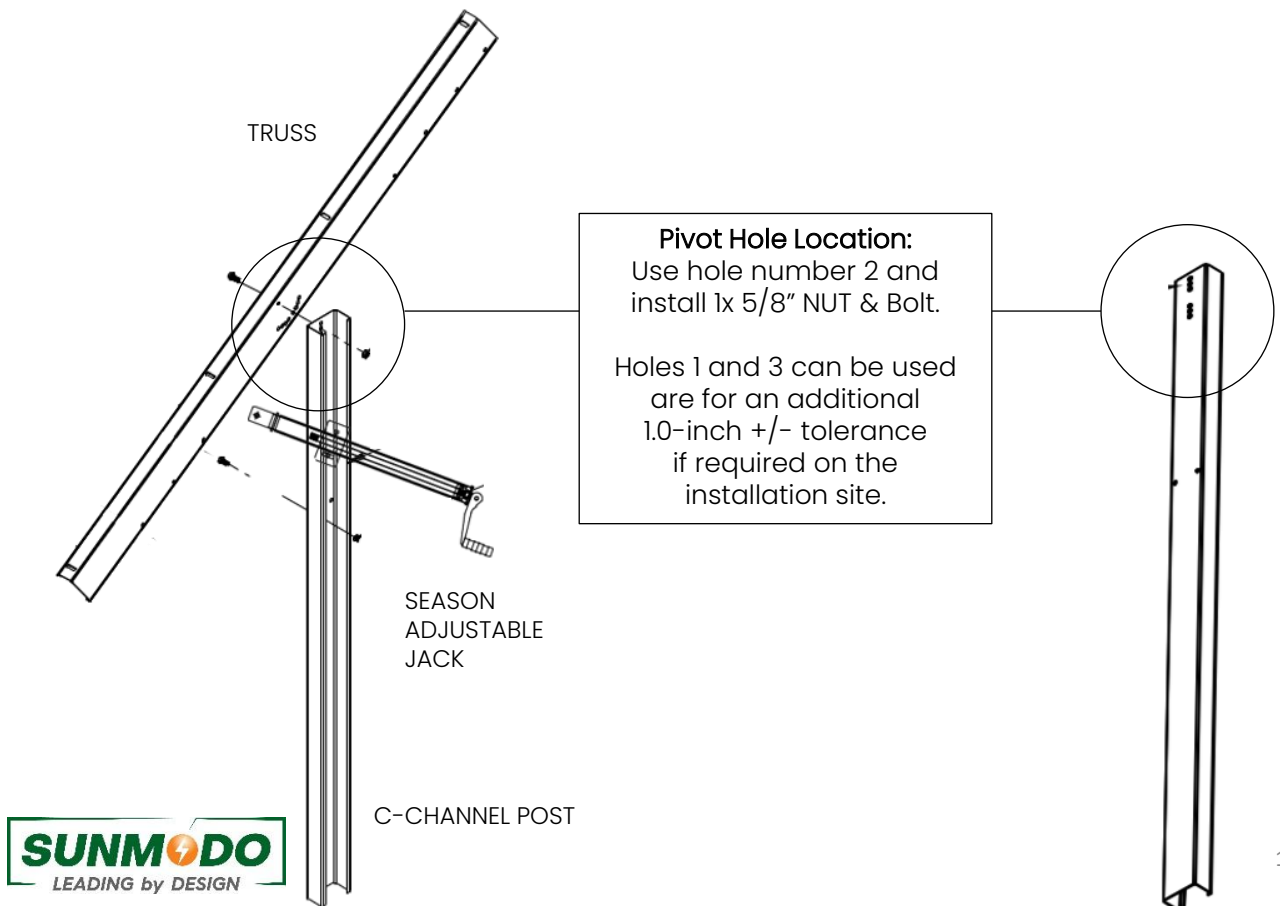

Z-PURLIN INSTALLATION

Z-PURLIN to TRUSS

Attach the four Z-PURLINS to the two TRUSSES with 1/2"-13 x 1-1/2" NUTS & BOLTS. Use a 3/4" hex socket and torque to 57 ft-lbs.

NOTE: Assemble the Z-PURLINS with the top flanges facing North.

STRONGBACK to Z-PURLIN (Optional)

Where required attach the STRONGBACK to the four Z-PURLINS with 4x 1/2"-13 x 1-1/2" NUTS & BOLTS. Use a 3/4" hex socket and torque to 57 ft-lbs.

NOTE: The STRONGBACK is usually required in regions identified as High-Velocity Hurricane Zones (HVHZ), or regions with high snow loads. Consult a licensed Professional Engineer to determine if the STRONGBACK is necessary.

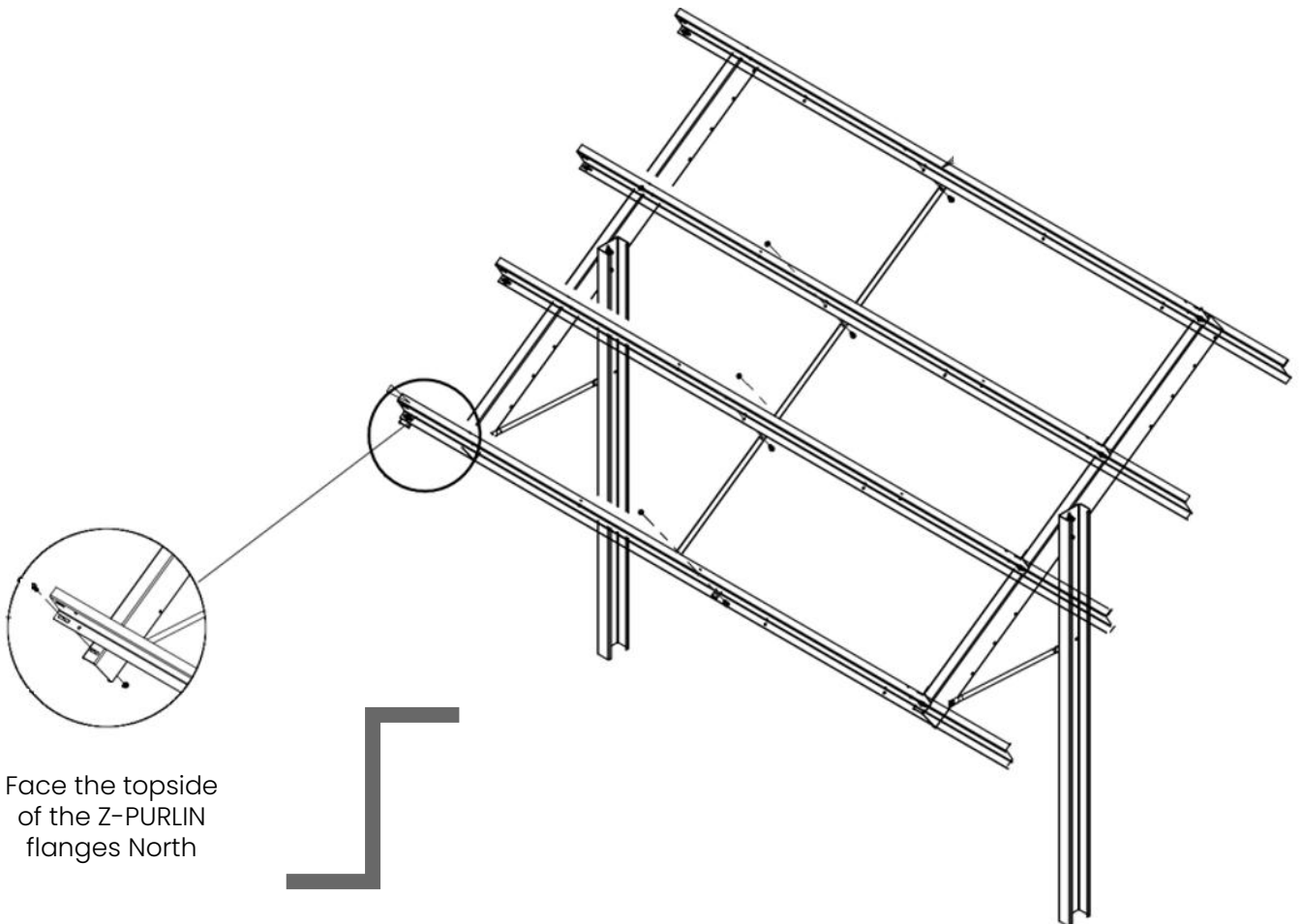

Z-PURLIN ASSEMBLY

Z-PURLIN Overlap

Attach the four Z-PURLINS to the two TRUSSES with 1/2"-13 x 1-1/2" NUTS & BOLTS. Use a 3/4" hex socket and torque to 57 ft-lbs.

NOTE: Overlap the Z-PURLINS (214" and 186") by 2-inches and secure using 2x 1/2"-13 x 1-1/2" NUTS & BOLTS.

CANTILEVER EXTENSIONS

Four additional modules, one column on either side, can be added using CANTILEVER EXTENSIONS on the East & West ends of the arrays.

NOTE: Overlap the CANTILEVER Z-PURLINS (48.5" and 52.0") by 6-inches and secure using 2x 1/2"-13 x 1-1/2" NUTS & BOLTS. Use a 3/4" hex socket and torque to 57 ft-lbs.

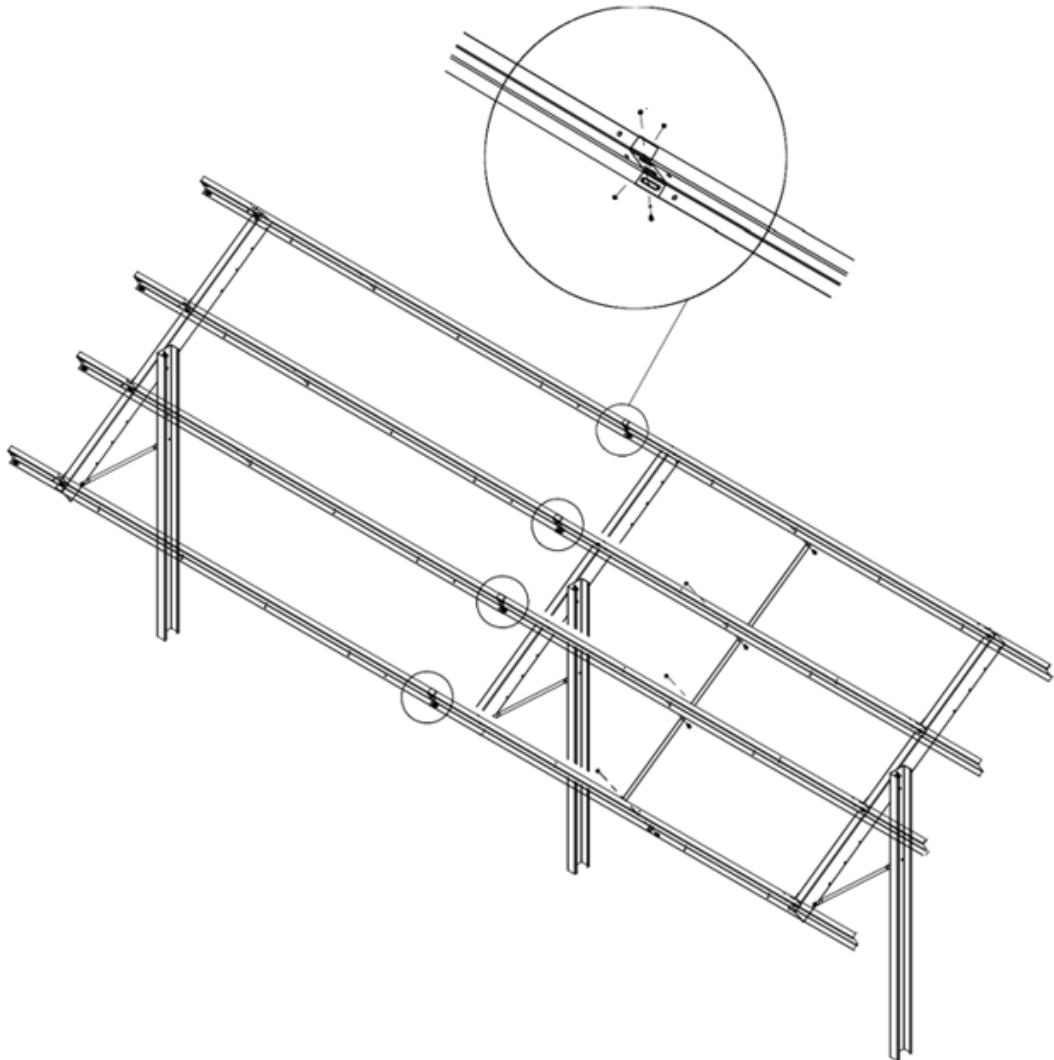

MODULE INSTALLATION

Module to Z-PURLIN using HARDWARE

Using the mounting holes in the module frame, attach the modules to the Z-PURLINS using two sets 5/16"-18 x 3/4" NUTS & BOLTS per side. Use a 1/2" hex socket and torque to 12 ft-lbs.

Module to Z-PURLIN using PANEL CLAMP ASSEMBLY

Attach the module to the Z-PURLINS using two PANEL CLAMPS per side. Use a 1/2" hex socket and torque to 10 ft-lbs.

NOTE: The minimum amount of racking is determined by [module width + 0.4-inch PANEL CLAMP width] multiplied by the number of modules.

NOTE: The PANEL CLAMP ASSEMBLY consists of three parts: 1x 5/16 x 2 1/2 Serrated Flanged Bolt - 1x UL Stainless Mid Clamp - 1x Tapped Aluminum Extrusion.

Modules to the Z-PURLINS
using two sets 5/16"-18 x 3/4"
NUTS & BOLTS shown

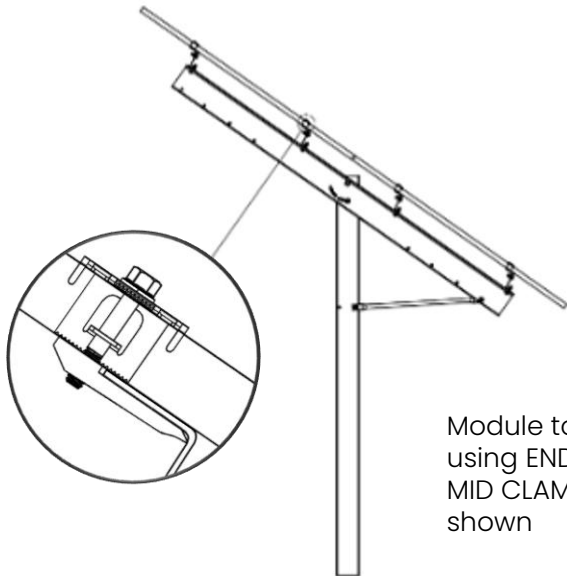
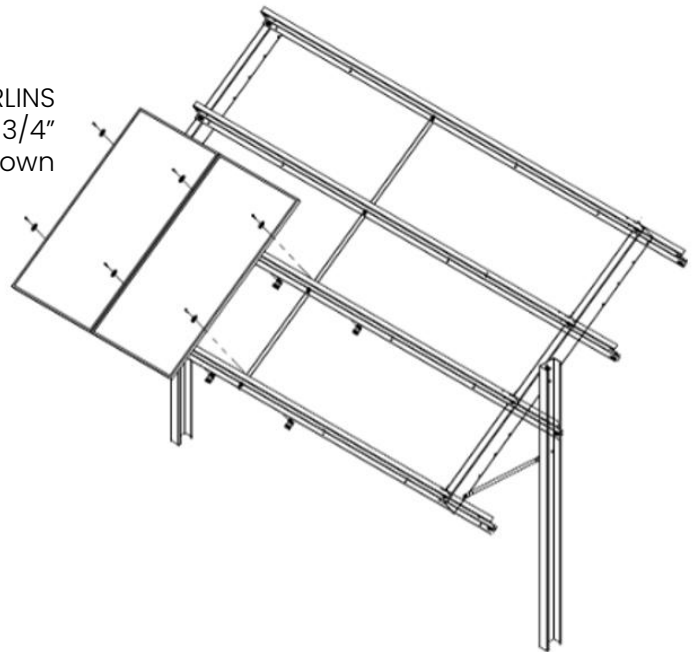

Module to Z-PURLIN
using END CLAMP and
MID CLAMP ASSEMBLIES
shown

DESIGN EXAMPLE

Documentation

Reference your SunModo drawing package that is specific to your project.

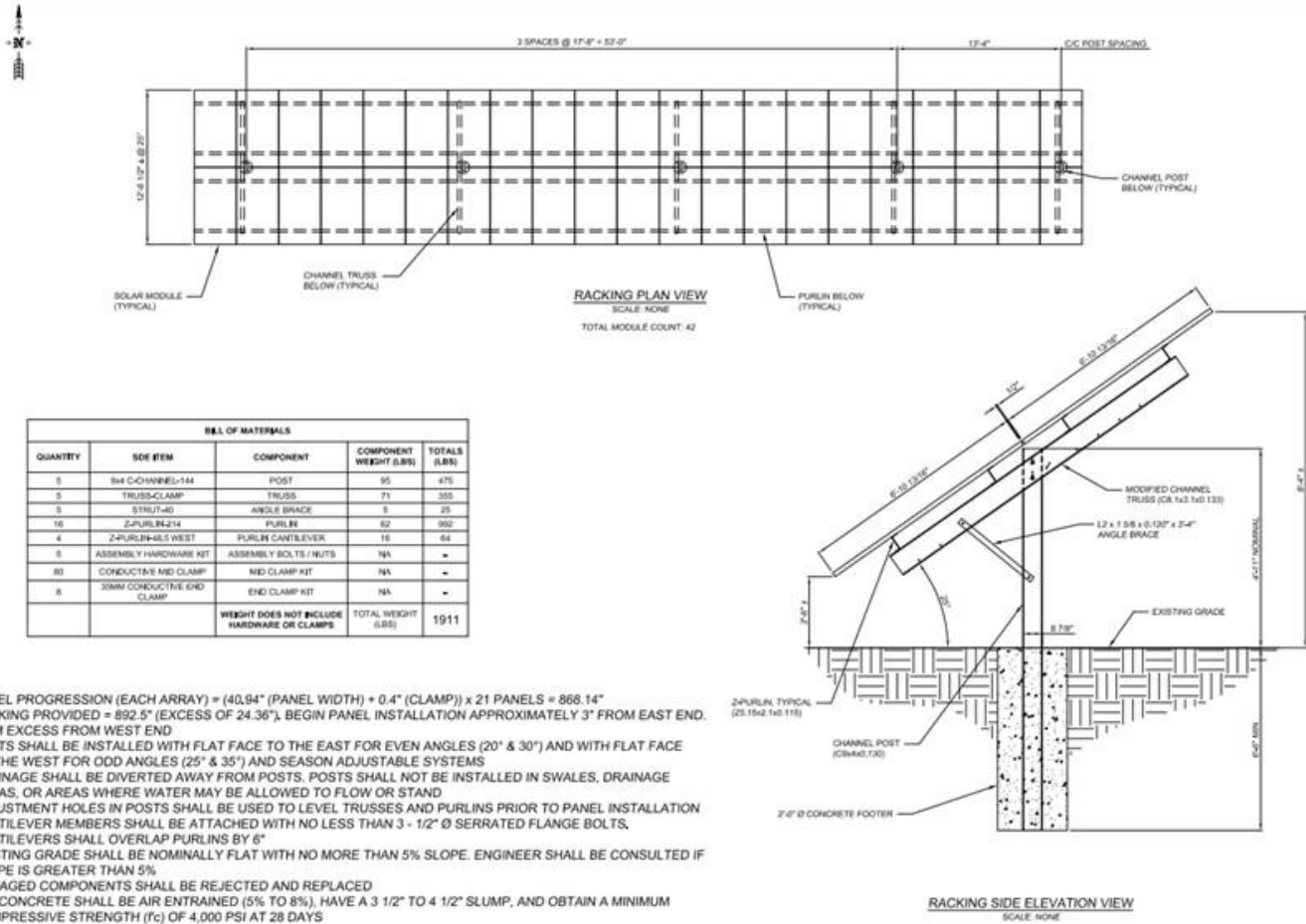

BILL OF MATERIALS				
QUANTITY	IDE ITEM	COMPONENT	COMPONENT WEIGHT (LBS)	TOTALS (LBS)
5	104 CHANNEL-144	POST	95	475
5	TRUSS-CLAMP	TRUSS	71	355
5	STRUT-40	ANGLE BRACE	5	25
10	2-PURLIN-214	PURLIN	82	992
4	2-PURLIN-48.5 WEST	PURLIN CANTILEVER	16	64
5	ASSEMBLY HARDWARE KIT	ASSEMBLY BOLTS / NUTS	NA	-
80	CONDUCTIVE MID CLAMP	MID CLAMP KIT	NA	-
5	30MM CONDUCTIVE END CLAMP	END CLAMP KIT	NA	-
		WEIGHT DOES NOT INCLUDE HARDWARE OR CLAMPS	TOTAL WEIGHT (LBS)	1911

- NOTES**
- PANEL PROGRESSION (EACH ARRAY) = (40.94" (PANEL WIDTH) + 0.4" (CLAMP)) x 21 PANELS = 868.14"
 - RACKING PROVIDED = 892.5" (EXCESS OF 24.36"). BEGIN PANEL INSTALLATION APPROXIMATELY 3" FROM EAST END. TRIM EXCESS FROM WEST END
 - POSTS SHALL BE INSTALLED WITH FLAT FACE TO THE EAST FOR EVEN ANGLES (20° & 30°) AND WITH FLAT FACE TO THE WEST FOR ODD ANGLES (25° & 35°) AND SEASON ADJUSTABLE SYSTEMS
 - DRAINAGE SHALL BE DIVERTED AWAY FROM POSTS. POSTS SHALL NOT BE INSTALLED IN SWALES, DRAINAGE AREAS, OR AREAS WHERE WATER MAY BE ALLOWED TO FLOW OR STAND
 - ADJUSTMENT HOLES IN POSTS SHALL BE USED TO LEVEL TRUSSES AND PURLINS PRIOR TO PANEL INSTALLATION
 - CANTILEVER MEMBERS SHALL BE ATTACHED WITH NO LESS THAN 3 - 1/2" Ø SERRATED FLANGE BOLTS. CANTILEVERS SHALL OVERLAP PURLINS BY 6"
 - EXISTING GRADE SHALL BE NOMINALLY FLAT WITH NO MORE THAN 5% SLOPE. ENGINEER SHALL BE CONSULTED IF SLOPE IS GREATER THAN 5%
 - DAMAGED COMPONENTS SHALL BE REJECTED AND REPLACED
 - ALL CONCRETE SHALL BE AIR ENTRAINED (5% TO 8%), HAVE A 3 1/2" TO 4 1/2" SLUMP, AND OBTAIN A MINIMUM COMPRESSIVE STRENGTH (fc) OF 4,000 PSI AT 28 DAYS

FAULT CURRENT PATH DIAGRAM

Electrical Bonding Components

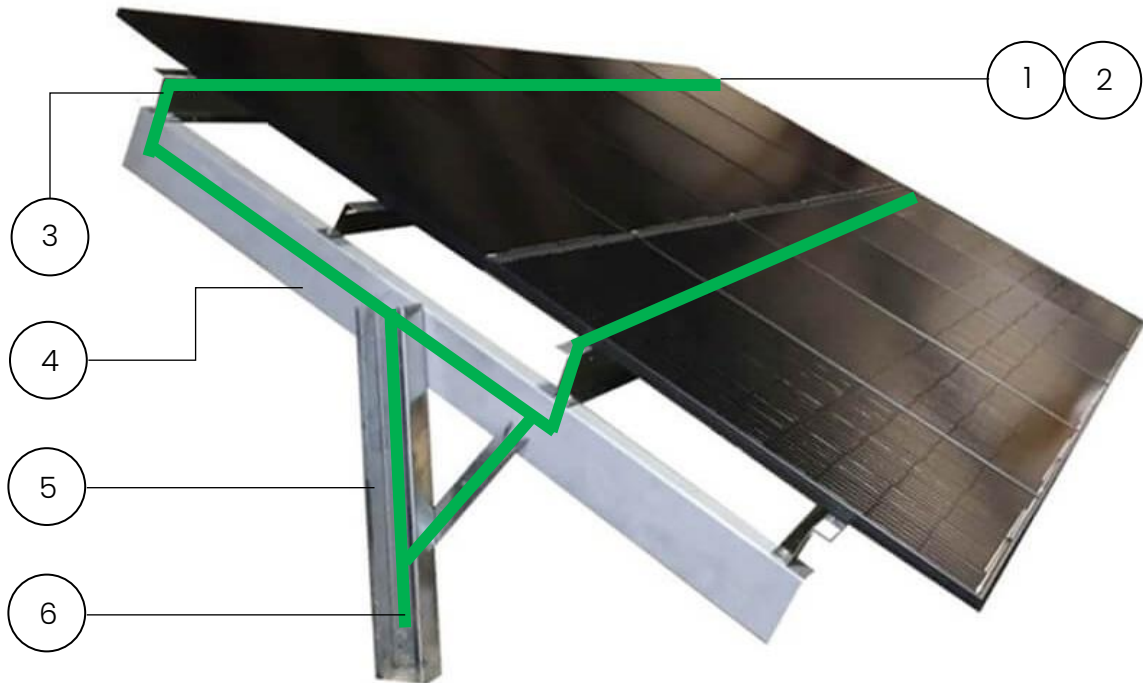

Items are listed in the fault current path in order from the PV Panel to the Grounding Lug:

1. PV Module
2. 5/16"-18 Serrated Flange Nuts & Serrated Flanged Hex Bolts
3. Z-Purlins
4. Trusses and Support Struts
5. C-Channel Posts
6. Ground Lug

Fault Current Path 

ELECTRICAL SAFETY AND GUIDELINES

Bonding & Grounding

The entire SunPier ground mount PV array has been classified for bonding & grounding in accordance with UL2703. The bonding path has been evaluated from the PV module frame to the C-CHANNEL PILE. The following are suggestions to aid in grounding of the PV array for the project electrical engineer of record, and by the local AHJ (authority having jurisdiction).

Any UL 1703/IEC 61730 compliant PV module secured to the steel structure using 5/16"-18 x 3/4" Serrated Flange Bolts and Serrated Flange Nuts and torqued to 12 ft-lbs is electrically bonded to the PV array per UL 2703.

If the UL 1703/IEC 61730 compliant PV modules are secured to the steel structure using the End and Mid Clamps only specific modules have been evaluated for bonding & grounding in compliance with UL2703. Reference the list of UL 2703 Qualified Modules included in this manual.

Attach one (1) GROUND LUG per ground mount PV array. Installation must be in accordance with NFPA NEC70, however the electrical designer of record should refer to the latest revision of National Electrical Code (NEC) for actual grounding conductor cable size. It is the installer's responsibility to check local codes, which may vary.

CAUTION: PV module removal may disrupt the bonding path and could introduce the risk of electric shock. Additional steps may be required to maintain the bonding path. PV modules should only be removed by qualified personnel.

Option 1: Array bonding/grounding can be achieved by installing one Ground Lug to any structural component of the array. Drill a 3/8" hole into the metal at the desire location and attach the Ground Lug. Using one solid or stranded copper wire (14 AWG to 6 AWG), or two copper wires (12 AWG to 10 AWG) secured by a 1/4"-28 stainless steel screw, horizontal to the tang per NEC 690.47.

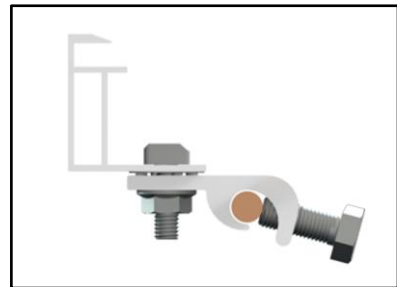
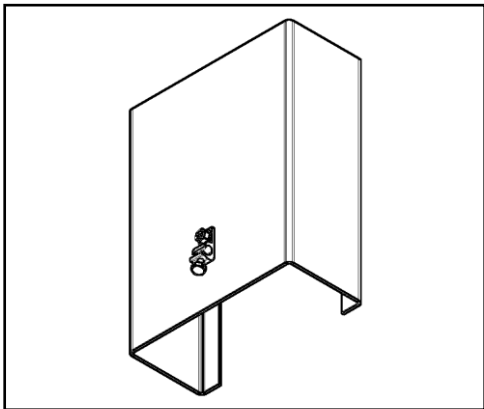

Option 2: Alternatively, the picture shows a Grounding Lug mounted on the module frame and one solid or stranded copper wire (14 AWG to 6 AWG), or two copper wires (12 AWG to 10 AWG) secured by a 1/4"-28 stainless steel screw, horizontal to the tang per NEC 690.47.

Reference the solar module manufacturer's instructions regarding attaching the Grounding Lug.

The SunPier system is for use with PV modules that have a maximum series fuse rating of 20A.

NOTE:

- Ensure bare copper grounding wire does not contact aluminum and steel components to prevent risk of galvanic corrosion.
- Any hole drilled to attach the Grounding Lug should be de-burred before use.
- Use anti-seize lubricant to prevent the stainless-steel Nuts and Bolts from seizing.

UL 2703 QUALIFIED MODULES

Manufacturer	Module Model Number / Series
Aionrise	AION60G1, AION72G1
Aleo	P-Series & S-Series
Aptos Solar	DNA-108-(MF/BF)10-xxxW DNA-120-(MF/BF)10-xxxW DNA-120-MF10, DNA-120-(MF/BF)23 DNA-144-(MF/BF)23, DNA-120-(MF/BF)26 DNA-144-(MF/BF)26
Astronergy	CHSM6612 M, M/HV CHSM6612P Series CHSM6612P/HV Series CHSM72M-HC CHSM72M(DG)/F-BH
Auxin	AXN6M610T AXN6M612T AXN6P610T AXN6P612T AXNG1M SERIES
Axitec	AC-xxx(M/P)/60S, AC-xxx(M/P)/72S AC-xxxP/156-60S AC-xxxMH/120(S/V/SB/VB) AC-xxxMH/144(S/V/SB/VB)
Bluesun Solar	HEX5 BSMxxxM10-54HPH BSMxxxM10-72HBD
Boviet Solar	BVM6610 BVM6612 BVM6612M-XXXS-H-HC-BF-DG BVM7612M-H-HC-BF-DG BYD P6K & MHK-36 Series
Canadian Solar	CS1(H/K/U/Y)-MS CS3K-(MB/MB-AG/MS/P/P HE/PB-AG) CS3L-(MS/P), CS3N-MS CS3U-(MB/MB-AG/MS/P/P HE/PB/PB-AG) CS6.1-54TM-H CS6.1-60TM-H CS6.1-72TB-H CS3W-(MB-AG/MS/P/P-PB-AG) CS3Y-MB-AG, CS5A-M CS6K-(M/MS/MS AllBlack/P/P HE) CS6P-(M/P) CS6R-MS CS6R-xxxMS-HL CS6U-(M/P/P HE) CS6W-(MS/MB-AG) CS6X-P CS7N-xxxTB-AG CS7N-xxxMB-AG CS7L-MB-AG CS7L-TB-AG CS7N-xxx MS CSX-P ELPS CS6(A/P)-MM
Centrosolar America	C-Series E-Series
CertainTeed	CT2xxMxx-01 CT2xxPxx-01 CTxxxMxx-01 CTxxxPxx-01 CTxxxMxx-02 CTxxxMxx-03 CTxxxMxx-04 CTxxxHC11-04 CTxxxMxx-04 CTxxxHC11-04 CTM10400HC11-08 CTM10400HC11-09 CTM10400HC11-06 CTxxxHC11-06
Eco Solargy	Orion 1000 Apollo 1000
EMMVEE	ExxxP72-B ExxxM72-B ExxxH CM120-B
ET Solar	ET AC Module ET Module ET-M772BH520-550WW/WB
First Solar	FS-6XXX(A) FS-6XXX(A)-P FS-6XXX(A)-P-I
Flextronics	FXS-xxxBB
Freedom Forever	FF-MP-BBB-xxx FF-MP1-BBB-xxx
FreeVolt	PVGraf
GCL	GCL-P6 GCL-M6 Series
Hansol	TD-AN3 TD-AN4 UB-AN1 UD-AN1
Hanwha SolarOne	HSL 60
Heliene	36M 36P 60M 60P 72M 72P Series 144HC M6 144HC M10 SL Bifacial 156HC M10 SL Bifacial
HT-SAAE	HT60-156M-C HT60-156M(V)-C HT72-156(M/P) HT72-156P-C HT72-156P(V)-C HT72-156M(PDV)-BF HT72-156M(PD)-BF HT72-166M HT72-18X
Hyperion Solar	HY-DH108P8(B) HY-DH108N8B HY-DH144P8 HY-DH156N8 HY-DH156P8
Hyundai	Hi KG KI MG RG RI RW TG TI Series HiA-SxxxHG HiD-SxxxRG(BK) HiS-S400PI HiS-SxxxYH(BK) HiS-SxxxXG(BK) HiN-SxxxXG(BK)
Illuminate USA	IL8-66HGD-xxx M IL5-72HBD-xxx M
Imperial Star	ISM7-SHDD108-400/M
Inception	mSolar 108BB HC Series (TXI10-xxx108BB) mSolar 144BB HC Series (TXS6-xxx144BB)
ITEK	iT-SE Series
Japan Solar	JPS-60 JPS-72 Series
JA Solar	JAM54S30 xxx/MR JAM54S31 xxx/MR JAM72D30 xxx/MB JAM78D10 xxx/MB JAM72S30/MR JAP6 60-xxx JAM6(K)-60/xxx JAP6(k)-72-xxx/4BB JAP72Sxx-xxx/xx, JAP6(k)-60-xxx/4BB, JAP60Sxx-xxx/xx JAM6(k)-72-xxx/xx, JAM72Sxx-xxx/xx JAM6(k)-60-xxx/xx JAM60Sxx-xxx/xx
Jinko	JKM JKMS Series JKMxxxM-72HL-V JKMxxxM-72HL4-(T)V JKMxxxM-72HLM-TV JKMxxxM-7RL3-V JKMxxxM-72HBL-V JKMxxxM-72HL4-TV JKMxxxM-6RL3-B JKMxxxN-72HL4-BDV JKMxxxN-54HL4-B JKMxxxN-72HL4-TV JKMxxxM-7RL3-TV
Kyocera	KD-F KU Series
LA Solar	LSxxxHC(166) LSxxxBF LSxxxBL LSxxxHC BLA Model
LG Electronics	LGxxx(A1C/M1C/M1K/N1C/N1K/Q1C/Q1K/QAC/QAK)-A6 LGxxxN2W-B3 LGxxxN2T-B5 LGxxxN1K-B6 LGxxx(E1C/E1K/N1C/N1K/N2T/N2W/S1C/S2W/Q1C/Q1K)-A5 LGxxx(M1C/N1C/Q1C/Q1K)-N5 LGxxx(N1C/N1K/N2T/N2W)-E6 LGxxx(N1C/N1K/N2W/Q1C/Q1K)-V5 LGxxx(N1C/N1K/N2W/S1C/S2W)-G4 LGxxx(N1K/N1W/N2T/N2W)-L5 LGxxxN2T-J5 LGxxxN3K-V6

UL 2703 QUALIFIED MODULES CONTINUED

Manufacturer	Module Model Number / Series
LONGi	LR4-60(HPB/HPH) LR4-72(HBD/HPH) LR5-54HABB-xxx M LR5-54HABB-xxx M LR5-54HPB-xxx M LR5-72HBD xxx M LR6-60 LR6-60(BK/HPB/HPH/HV/PB/PE/PH) LR6-72 LR6-72(BK/HBD/HV/PB/PE/PH) LR7-54HGGB-xxx M LR7-72HGD-xxx M LR8-66HGD-xxx M RealBlack LR4-60HPB RealBlack LR6-60HPB
Maxeon	SPR-MAX3-xxx-COM SPR-MAX3-XXX-R SPR-MAX3-XXX-BLK-R
Meyer Burger	Meyer Burger Black, Meyer Burger White Meyer Burger Glass
Mission Solar Energy	MSExxxSX9R MSE Mono MSE Perc MSExxx(SR8T/SR8K/SR9S/SX5T) MSExxx(SX5K/SX6W) MSExxxSX6Z MSExxxHT0B Mitrex Mxxx-L3H Mxxx-I3H
Mitsubishi	MJE MLE Series
mSolar	TXI10-xxx108BB
Neo Solar Power Co.	D6M Series
NE Solar	NESE xxx-72MHB-M10 NESE xxx-60MH-M6 NESE XXX 72MHT-M10 NESE XXX 72THB-M10 NESE XXX 72MHB-M10
Panasonic	VBHNxxxSA06/SA06B/SA11/SA11B VBHNxxxSA15/SA15B/SA16/SA16B VBHNxxxKA VBHNxxxKA03/04 VBHNxxxSA17/SA17G/SA17E/SA18/SA18E VBHNxxxZA01/ZA02/ZA03/VBHNxxxZA04 EVPVxxx EVPVxxx(H/K/PK/HK/HK2)
Peimar	SGxxxM (FB/BF) SMxxxM
Philadelphia Solar	PS-M108(HCBF)-xxxW
Phono Solar	PSxxxM1-20/U PSxxxM1H-20/U PSxxxM1-20UH PSxxxM1H-20UH PSxxxM1-20/UH PSxxxM1H-20/UH PSxxxM-24/T PSxxxMH-24/T PSxxxM-24/TH PSxxxMH-24/TH PSxxxM4(H)-24/TH
Prism Solar	P72 Series P72X-xxx
Q Cells	Peak G5(SC) , G6(+)(SC)(AC), G7, G8(+) Peak L-G5, L-G6, L-G7, L-G8(BFF) Plus, Pro, Peak, G3, G4 Plus, Pro, Peak L-G2, L-G4, L-G5 Q.PEAK DUO (BLK)-G6+ Q.PEAK DUO (BLK)-G7 Q.PEAK DUO (BLK) G8(+) Q.PEAK DUO (BLK) ML-G10(a)(+) Q.PEAK DUO (BLK) ML-G9(+) Q.PEAK DUO BLK G10(+) Q.PEAK DUO BLK G10+ /AC Q.PEAK DUO BLK-G6+/TS Q.PEAK DUO BLK ML-G10.B+ Q.PEAK DUO BLK ML-G10+ / t Q.PEAK DUO BLK ML-G10+ / TS Q.PEAK DUO G10+ Q.PEAK DUO L-(G7/G7.1/G7.2/G7.3/G7.7) Q.PEAK DUO L-(G8/G8.1/G8.2/G8.3) Q.PEAK DUO L-G6.3 / BFG Q.PEAK DUO L-G8.3 BFG/BGT Q.PEAK DUO XL-(G10/G10.2/G10.3/G10.c/G10.d) Q.PEAK DUO XL-(G11.2/G11.3) Q.PEAK DUO XL-(G9/G9.2/G9.3) Q.PEAK DUO XL-G10.3/BFG Q.PEAK DUO XL-G10.d/BFG Q.PEAK DUO XL-G11.3/BFG Q.PEAK DUO XL-G11S.3 / BFG Q.PEAK DUO XL-G9.3 BFG Q.TRON BLK M-G2+ AC Q.TRON BLK M-G2+ SERIES Q.TRON M-G2+ SERIES Q.TRON XL-G2.3/BFG
REC	RECxxxAA (BLK/Pure/Pure-R/ Pure-RX/ Pure2/ Pro M) RECxxxNP (N-PEAK) RECxxxNP2 (Black) RECxxxNP3 Black RECxxxPE, RECxxxPE72 RECxxxTP, RECxxxTP72 RECxxxTP2(M/BLK2) RECxxxTP2S(M)72 RECxxxTP3M (Black) RECxxxTP4 (Black)
Renesola	All 60-cell modules
Risen	RSM Series RSM110-8-xxxBMDG
SEG Solar	SEG-xxx-BMD-HV SEG-xxx-BMD-TB SEG-XXX-BMB-TB SEG-xxx-BMA-HV SEG-xxx-BMA-TB SEG-xxx-BMB-HV SEG-xxx-BMA-BG SEG-xxx-BMB-BG SEG-xxx-BTA-BG SEG-xxx-BTB-BG SEG-xxx-BMD-BG SEG-xxx-BTD-BG
S-Energy	SN72 SN60 Series SL45-60BGI/BHI SL45-60MBI-xxxZ
Seraphim	SEG-(6PA/6PB/6MA/6MA-HV/6MB/E01/E11) SRP-(6QA/6QB) SRP-xxx-6MB-HV SRP-320-375-BMB-HV SRP-xxx-BMC-HV SRP-390-450-BMA-HV SRP-xxx-BMZ-HV SRP-390-405-BMD-HV
Sharp	NU-SA NU-SC Series
Silfab	SLA-M SLA-P SLG-M SLG-P BC Series SILxxx(BG/BK/BL/HC/HC+/HL/HM/HN/ML/NL/NT/NX/NU/QD/QM) SIL-xxx XM, SIL-xxx XM+
Sirius	ELNSM72M-HC Series ELNSM54M-HC Series
Solar4America	S4Axxx-108MH10BB S4Axxx-72MH5BB S4Axxx-144MH10xxx S4Axxx-144TH10xxx S4Axxx-144TH16xxx S4Axxx-108MH10xxx S4Axxx-108TH10xxx
SolarEver USA	SE-166*83-xxxM-120N SE-182*91-xxxM-108N
Solaria	PowerXT-xxxR-(AC/PD/BD) PowerXT-xxxR-PM (AC) PowerX-400R
Solartech	STU HJT STU PERC Quantum PERC
SolarWorld	Sunmodule Protect Sunmodule Plus/Pro
Sonali	SS-M-360 to 390 Series SS-M-390 to 400 Series SS-M-440 to 460 Series SS-M-430 to 460 BiFacial Series
Sun Edison	F-Series R-Series
Suniva	MV Series Optimus Series (35mm)
Sunmac Solar	M754SH-BB Series

UL 2703 QUALIFIED MODULES CONTINUED

Manufacturer	Module Model Number / Series
SunPower	AC, X-Series E-Series P-Series SPR E20 435 COM (G4 Frame) Axxx-BLK-G-AC SPR-Mxxx-H-AC SPR-Mxxx-H-AC SPR-Mxxx-BLK-H-AC
Suntech	STP STPXXXS - B60/Wnhb
Talesun	TP572 TP596 TP654 TP660 TP672 TP6L72M-450 Hipor M Smart TD6I72M TP7G54M(H) TD7G72M
Tesla	SC SC B SC B1 SC B2 TxxxS TxxxH
Thornova	TS-BG54
Trina	DE09.05 DE09C.07 DEG15HC.20(II) DEG15MC.20(II) DEG15VC.20(II) DE18M(II) DEG18MC.20(II) DE19 DEG19C.20 PA05 PD05 DD05 DD06 DE06 PD14 PE14 DD14 DE14 DE15 DE15V(II) TSM-DE09.08 TSM-DE09C.07 TSM-DE09.05 TSM-DEG21C.20 TSM-NE09RC.05 TSM-NEG19RC.20 TSMC TS-150C2 CIGSw
Universal Solar	UNI4xx-144BMH-DG UNI5xx-144BMH-DG UNIxxx-108M-BB UNIxxx-120M-BB UNIxxx-120MH Upsolar UP-MxxxP UP-MxxxM(-B)
URECO	D7Kxxx(H7A/H8A) D7Mxxx(H7A/H8A) F6MxxxE7G-BB FAKxxx(C8G/E8G) FAMxxxE7G-BB FAMxxxE8G(-BB) FBKxxxM8G FBMxxxM7G-BB FBMxxxMFG-BB
Vikram Solar	Eldora Somera Ultima PREXOS VSMDHT.60.AAA.05 PREXOS VSMDHT.72.AAA.05 Paradea VSMDH.72.AAA.05
Vina	VNS-72M1-5-xxxW-1.5 VNS-72M3-5-xxxW-1.5 VNS-144M1-5-xxxW-1.5 VNS-144M3-5-xxxW-1.5 VNS-120M3-5-xxxW-1.0
VSUN	VSUNxxx-60M-BB, VSUNxxx-72MH VSUN4xx-144BMH VSUN4xx-144BMH-DG VSUN5xx-144BMH-DG VSUNxxx-108M-BB VSUNxxx-120M-BB VSUNxxx-120BMH VSUNxxx-132BMH VSUNxxx-108BMH VSUNxxxN-144BMH VSUNxxxN-144MH VSUNxxx-144BMH VSUNxxx-144MH VSUNxxx-144M-BW VSUNxxx-144M-BB
Waaree	Ahnay Series Bi-33 Arka Series WSMDi
Winaico	WST Series WSP Series
Yingli	YGE Series YLM Series
Yotta Energy	YSM-B450-1
ZNShine Solar	ZXM7-SHLDD144 ZXM7-SHDB144 ZXM6-72 Series ZXM6-NH144 ZXM6-NHLDD144 ZXM7-SH108 Series ZXM7-UHLDD144