

NANORACK™ SYSTEM

PRODUCT INSTALLATION MANUAL



TABLE OF CONTENTS

2 – TABLE OF CONTENTS	17 – WIRE MANAGEMENT ACCESSORIES
3 – NANORACK SYSTEM OVERVIEW	18 – FAULT CURRENT PATH DIAGRAM
4 – UL 2703 CERTIFICATION	19 – UL 2703 QUALIFIED MODULES
4 – INSTALLER’S RESPONSIBILITY	20 – METAL ROOF ATTACHMENT ADDENDUM
5 – SYSTEM COMPONENTS	21 – FIRST ROW & FIRST MODULE ATTACHMENT
6 – RECOMMENDED TOOLS	22 – ADDENDUM: STAGGERED MODULES
7 – MODULE PLACEMENT	
7 – NANOPLUS ORIENTATION	
8 – GROUNDWORK FIRST ROW	
9 – GROUNDWORK ADDITIONAL ROWS	
10 – GROUNDWORK VERIFICATION	
10 – GROUNDWORK MLPE ASSEMBLY	
11 – ROOFWORK FIRST ROW	
12 – ROOFWORK ADDITIONAL ROWS	
13 – ROOFWORK ADDITIONAL ROWS	
14 – SKIRT INSTALLATION (OPTIONAL)	
15 – SKIRT INSTALLATION (OPTIONAL)	
16 – SKIRT INSTALLATION (OPTIONAL)	

THROW YOUR TAPE MEASURE AWAY:

SunModo proudly introduces NanoRack. There isn't any rail, but it isn't like any other rail-less system on the market. NanoRack not only addresses the issues that plague other rail-less systems, but it is also easier and faster to install than rail systems. Since most of the assembly takes place on the ground, the NanoRack is the fastest solar panel roof attachment system on the market. Simply lay out the first row of modules then install the remaining modules up the roof in a heel-toe fashion. The NanoRack universal brackets use a patent pending hook and loop assembly method which electrically bonds each column of modules together as they are installed. The module bonding jumper slides onto the frame of the solar panels, bonding module columns E-W. The optional Skirt is easily installed and gives the NanoRack System that professional finished look either on just the front edge, or around the entire perimeter of the array.

NANO RACK SYSTEM OVERVIEW:

- 1" vertical adjustment for leveling on uneven roofs
- E-W module bonding via Skirt or optional Bonding Jumpers.
- N-S module bonding using a patent pending hook and loop clamp system.
- Heel-toe PV module assembly up the roof slope.

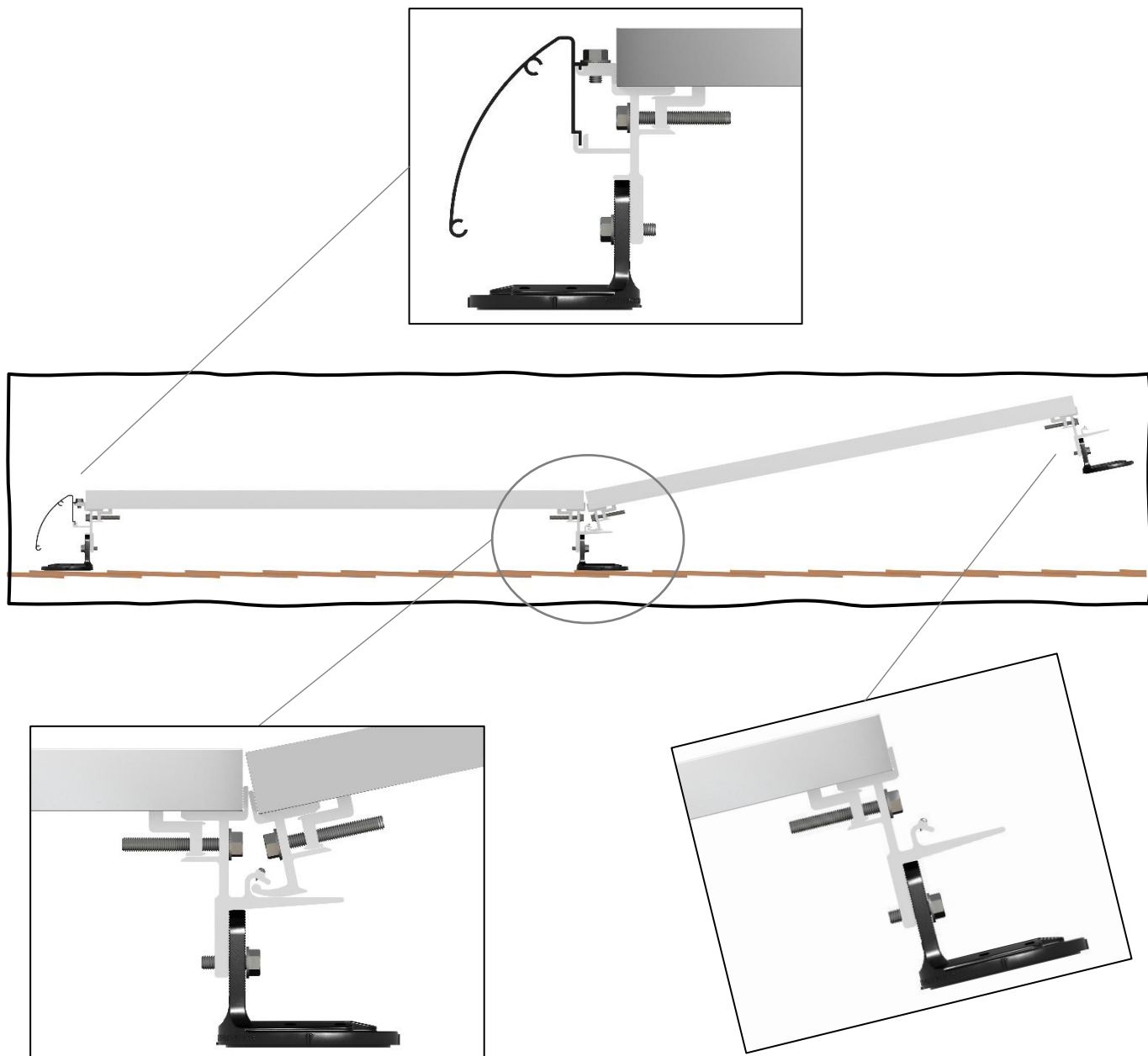

UL2703 CERTIFICATION

SunModo's NanoRack System can be used to mount photovoltaic (PV) modules onto a wide variety of residential roof tops. These installation instructions are of a general nature for attaching the NanoRack System onto residential pitched roofs. All installations shall be in accordance with NEC requirements in the USA. NanoRack's self-bonding system is for use with PV modules that have a maximum series fuse rating of 30A.

Mechanical design Loads per UL 2703: Downward Pressure: 16.7Psf(800Pa), Upward Pressure: 16.7Psf(800Pa), Down-Slope: 5Psf(239.4Pa)

The NanoRack System is tested and recognized to UL 2703 standards for safety grounding and bonding equipment and meets UL 1703 fire standards.

The grounding of the entire system is intended to be in accordance with the latest edition of the National Electrical Code, including NEC 250: Grounding and Bonding, and NEC 690: Solar Photovoltaic Systems or Canadian Electrical Code Part 1, CSA 22.1: Safety Standard for Electrical Installations. Any local electrical codes must be adhered in addition to the national electrical codes.

INSTALLER'S RESPONSIBILITY

- Installer shall employ only SunModo products detailed herein. The use of non SunModo components can cancel the letters of UL compliance and product warranties.
- Installer is responsible to determine that the roof, its rafters, connections, and other structural components can sustain the array under all environmental loading conditions per the codes and standards; consult with a licensed professional engineer.
- Installer shall guarantee that screws have adequate pullout strength and shear capacities.
- Installer shall adhere to the torque values specified in this Instruction Manual.
- Installer is responsible to install solar panels over a fire-resistant roof covering rated for the application.
- Installer shall adhere to all relevant local or national building codes. If any details of these installation instructions conflict with code requirements, installer should consult with SunModo.
- Installer shall guarantee the safe placement of all electrical details of the PV array.
- Installer to follow all applicable safety requirements during installation.
- Installer shall ensure bare copper grounding wire does not contact aluminum and zinc-plated steel components to prevent risk of galvanic corrosion.
- Installer is responsible for and shall provide an appropriate method of direct-to-earth grounding according to the latest edition of the National Electrical Code, including NEC 250: Grounding and Bonding, NEC 690: Solar Photovoltaic Systems.
- Installer shall comply with all applicable local, state and national building codes, including periodic re-inspection of the installation for loose components, loose fasteners, and any corrosion. If loose components or loose fasteners are found during periodic inspection, re-tighten immediately. If corrosion is found, replace affected components immediately.
- It is recommended that anti-seize compound be applied to the screw threads.



SYSTEM COMPONENTS



Universal Bracket
NANORACK-UNI
K10530-001



Module Hook
NANORACK-HOOK
K10531-001



NanoPlus
NANOPLUS-B
K50064-BK1



Deck Screw
SCREW-B
K50055-BK2

Skirt Clamp
SKIRT-CLAMP
K10532-001

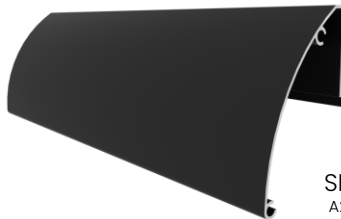

Skirt
SKIRT-84-B
A20516-084-BK

Outer Corner
SKIRT-OUTER-B
K10524-BK2

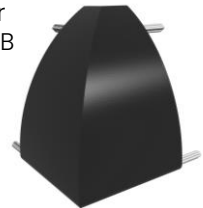

Skirt Splice Clamp
SKIRT-SPLICE
K10532-002



End Cap
SKIRT-CAP-B
C10063-BK1

Inner Corner
SKIRT-INNER-B
K10523-BK2



End Bracket
NANORACK-END
K10529-BK1



Grounding Lug
GRND-SMR
K10469-004



MLPE Mount, Module
MLPE-MODULE
K10526-001

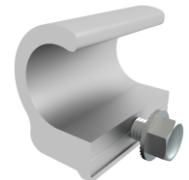

1" Conduit Clamp
CLMP-CON-100-S
K10429-002

3/4" Conduit Clamp
CLMP-CON-075-S
K10430-002



Heyco Edge Clips 1500 Series
Unassembled or Assembled with 8" Cable Tie

HellermannTyton Edge Clip (BX-CT-EC-PZ) and Cable Ties
(BX-CT-UV-PZ)

RECOMMENDED TOOLS



Band Saw



Impact Driver



Caulk Gun and Sealant
Such as:
ChemLink MI (for composite roofs)
ChemLink DuraLink (for metal roofs)



13mm
6-point
Socket



Tape Measure



Chalk Reel

MODULE PLACEMENT



NANOPLUS ORIENTATION

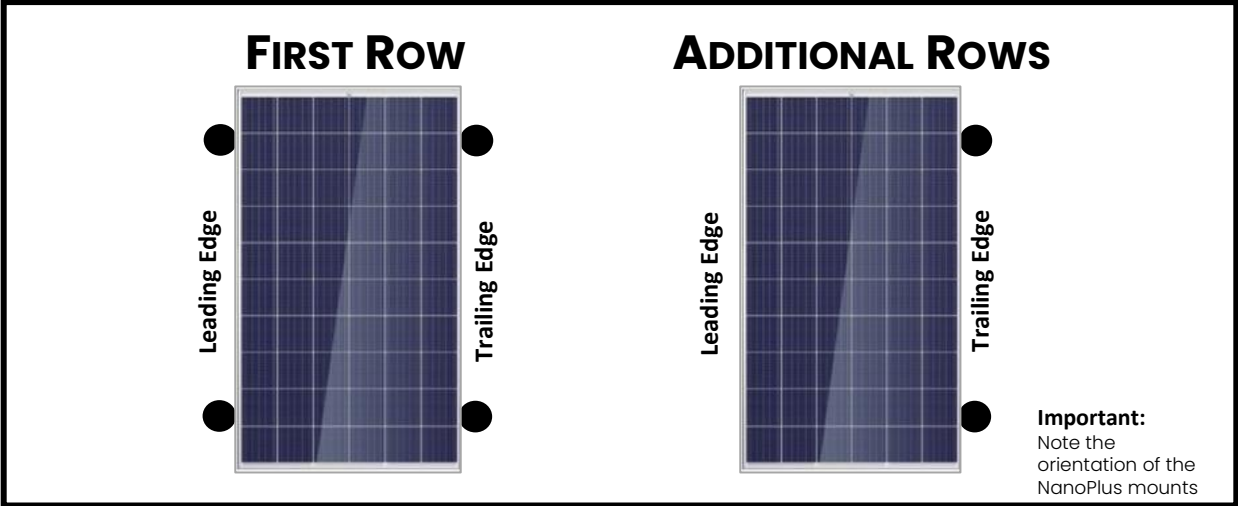

GROUNDWORK FIRST ROW

Use the module mounting holes as a visual reference to align and attach the NanoRack brackets.

Note: Modules can be secured using NanoRack brackets on either the long or short sides of the module. Reference the module manufacturer's instructions regarding the allowable clamping zones.

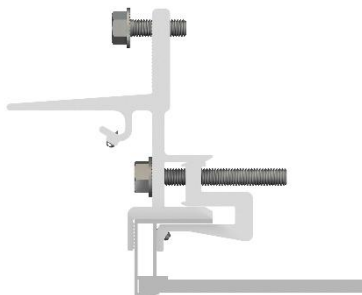
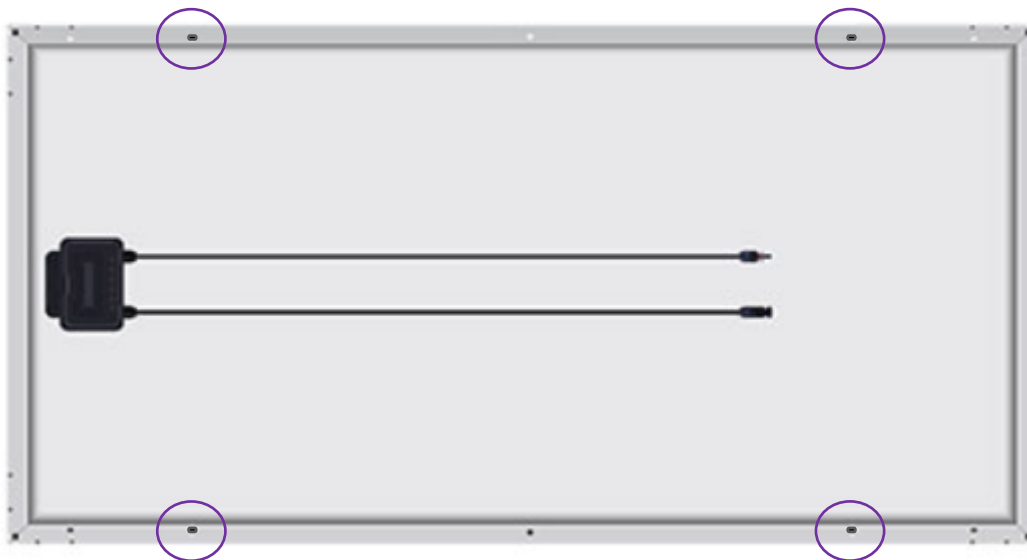

Attach four (4) Universal Brackets and torque to 13Nm (10 ft-lbs).

Note: The Universal Brackets can be installed adjacent to the mounting holes on the frame thereby leaving the mounting holes available for tie wrapping the wires to the module frame.



Attach four (4) NanoPlus mounts to the four (4) Universal Brackets and torque to 13Nm (10 ft-lbs).

IMPORTANT:
Note the orientation of the NanoPlus mounts.

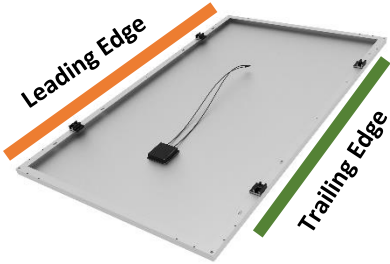

GROUNDWORK ADDITIONAL ROWS

	<p>Determine a “Leading Edge” and a “Trailing Edge” for the modules.</p> <p>The Leading Edge will be used to attach the Module Hooks.</p> <p>The Trailing Edge will be used to attach the Universal Brackets.</p> <p>Note: Modules can be secured using NanoRack brackets on either the long or short sides of the module. Reference the module manufacturer’s instructions regarding the allowable clamping zones.</p>
---	---

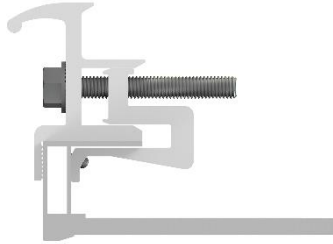
LEADING EDGE

		<p>Attach two (2) Module Hooks to the LEADING EDGE of the module and torque to 13Nm (10 ft-lbs).</p>
---	---	---

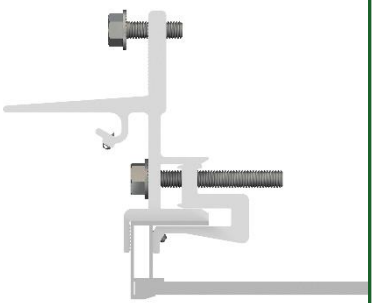
TRAILING EDGE

		<p>Attach two (2) Universal Brackets to the TRAILING EDGE of the module and torque to 13Nm (10 ft-lbs).</p> <p>Note: The Universal Brackets can be installed adjacent to the mounting holes on the frame thereby leaving the mounting holes available for tie wrapping the wires to the module frame.</p>
		<p>Attach two (2) NanoPlus mounts to the two (2) Universal Brackets and torque to 13Nm (10 ft-lbs).</p> <p>IMPORTANT: Note the orientation of the NanoPlus mounts.</p>

GROUNDWORK VERIFICATION

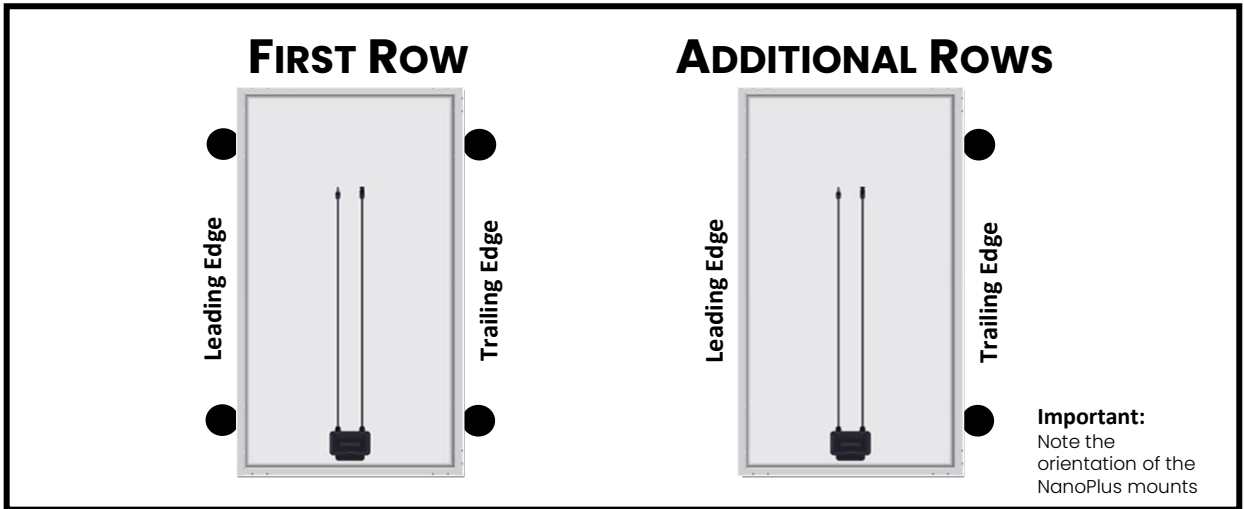

GROUNDWORK MLPE ASSEMBLY

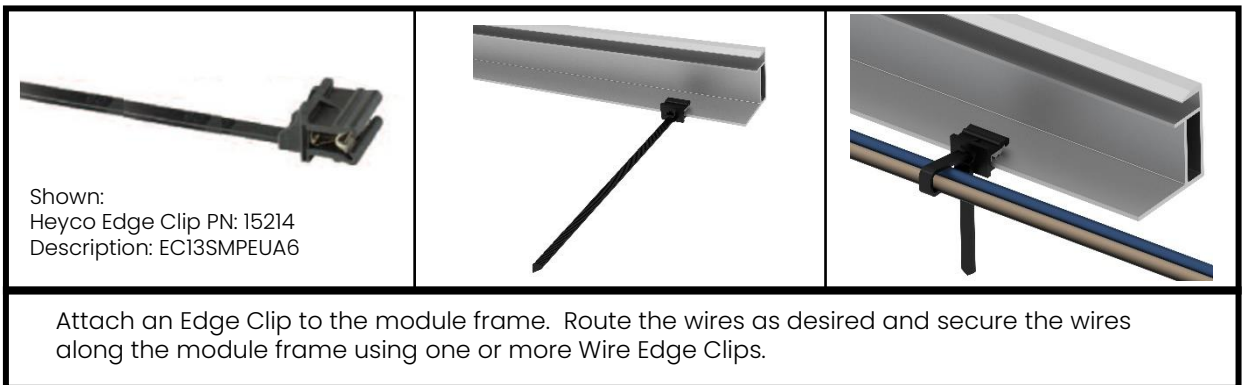
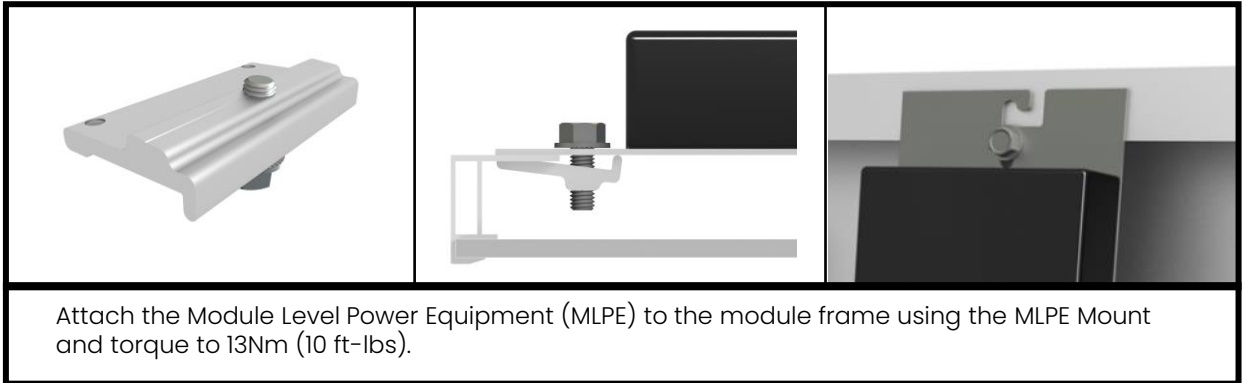

ROOFWORK FIRST ROW



Using your engineered design, determine the solar panel array placement on the roof.

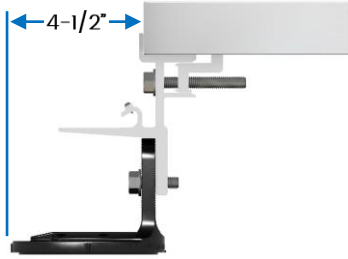

NOTE: The distance from the edge of the NanoPlus to the edge of the module is 4-1/2".

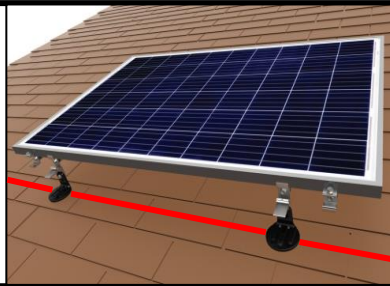

Identify the placement of the first row of modules and snap a line.

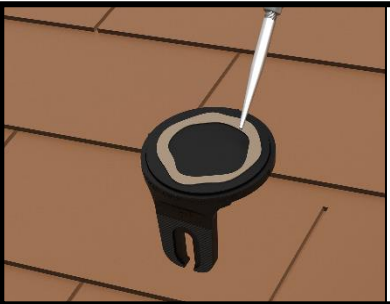

NOTE: The module is not shown for clarity.

Apply a circular bead of compatible roof sealant, such as Chem-link M1, around the bottom of the NanoMount.

OPTIONAL SEALANT APPLICATION: Apply a circular bead of sealant on the roof and install the NanoPlus in the sealant.

Apply additional sealant to the roof if needed to seal gaps between shingles or to smooth uneven surfaces.



NOTE: The module is not shown for clarity.

Attach the module to the roof by installing the four (4) Deck Screws into each of the four (4) NanoPlus mounts.

ROOFWORK ADDITIONAL ROWS

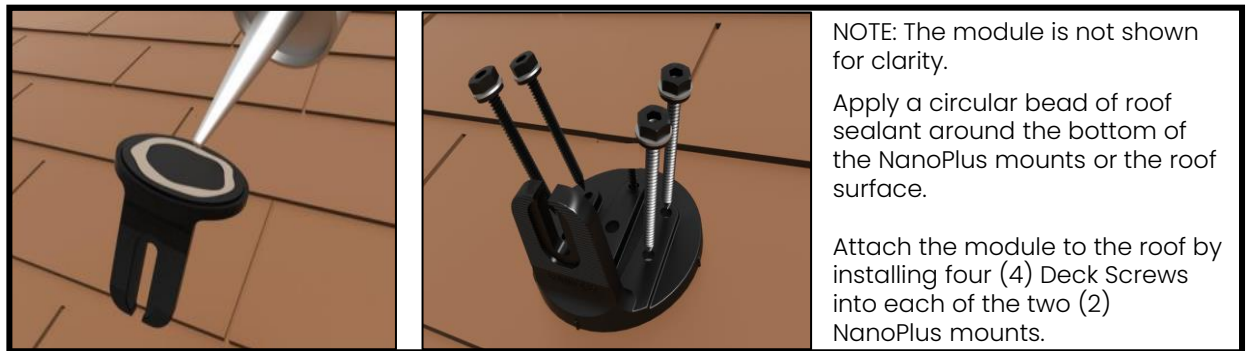
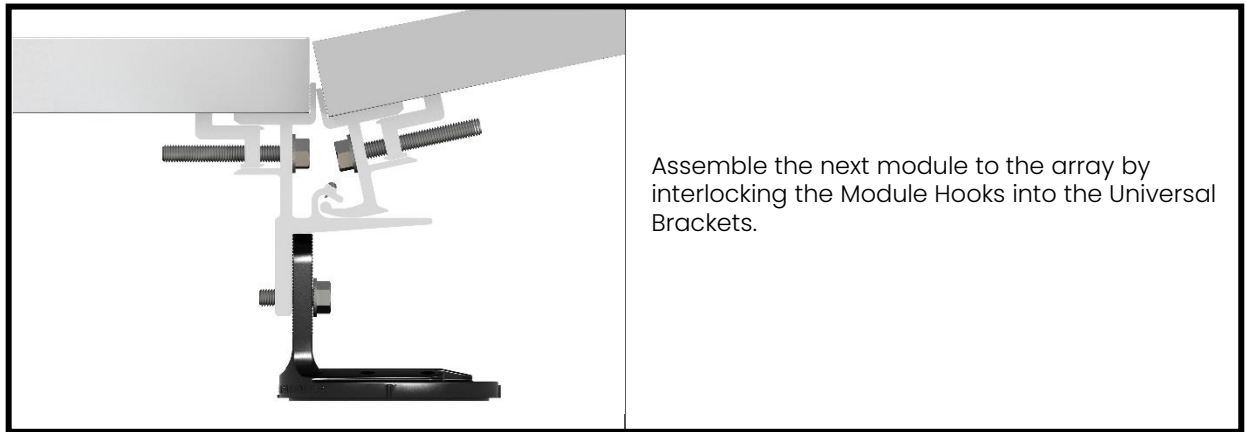

ROOFWORK ADDITIONAL ROWS

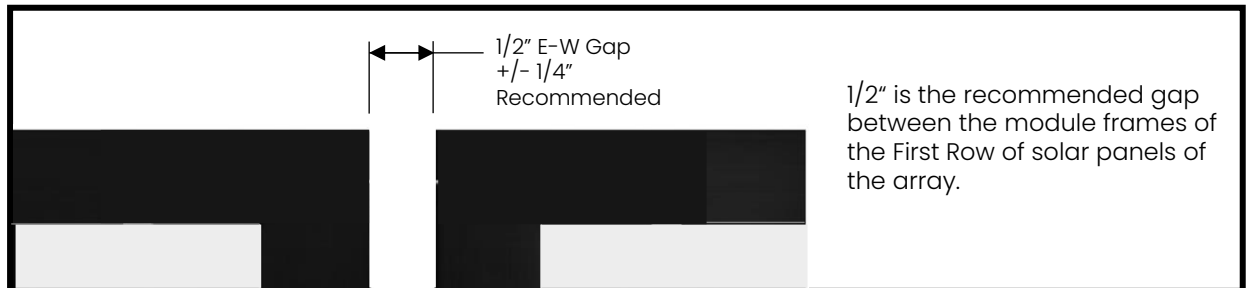
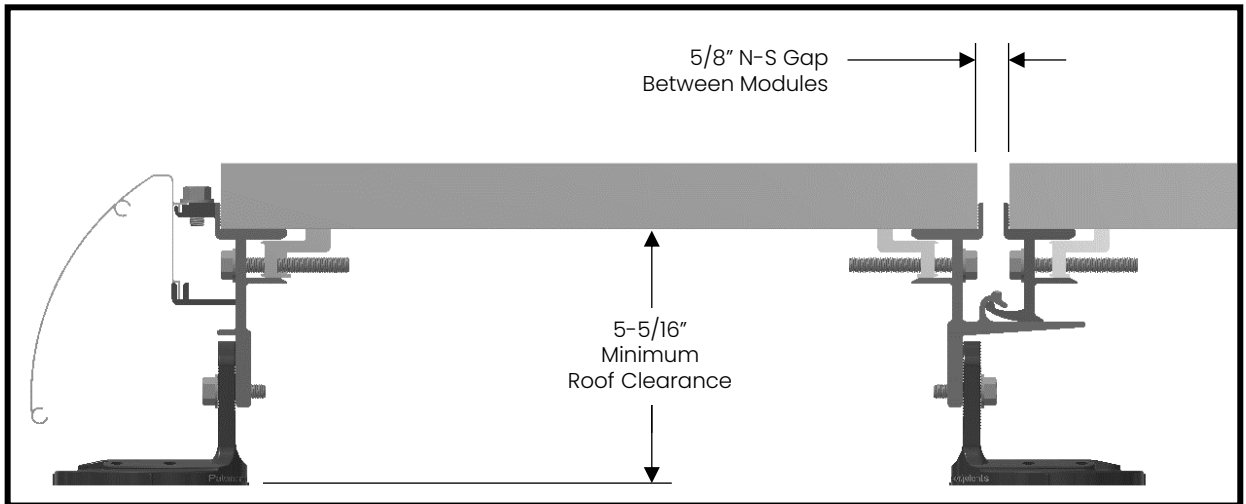

1/2" is the recommended gap between the module frames of the First Row of solar panels of the array.

Optional:
Two Adhesive-Backed Bumpers can be used to maintain east-west spacing between modules during assembly.



Part shown:
McMaster-Carr: 95495K932
Adhesive-Back Bumpers
Polyurethane Rubber, 21/32" OD,
13/32" High, Durometer 65A

Loose/sagging module cables can be secured to the module frame or NanoRack Brackets using Double Head Cable Ties.

Part shown:
Advance Cable Ties
PN: AL-11-50-DH-0-C
Double Head Cable Ties,
50 LB, 11 Inch, UV Black



Optional:
Loop two standard Cable Ties together. One Cable Tie can be used to gather the loose/sagging cable and the other can be pulled taut and secured to the module frame or NanoRack Bracket.

SKIRT INSTALLATION (OPTIONAL)



OPTION 1



OPTION 2



OPTION 3

SUNMODO OFFERS 3 SOLAR ARRAY FINISHING OPTIONS:

OPTION 1 | NO-SKIRT

If you decide to forego installing the Skirt on the solar array, we recommend the use of the black NanoRack End Brackets to give the leading edge of the array a finished look.



OPTION 2 | LEADING-EDGE SKIRT

SunModo offers End Caps which cover the ends of the Skirt giving the solar array a clean and professional finished look.

OPTION 3 | SKIRT-360

The Skirt has been designed to provide 360-degree skirting of the entire array if desired. The Inner Corners and Outer Corners provide the flexibility to attach the Skirt to the full perimeter of any shaped solar array. The Corners simply push into the ends of each Skirt run.

SKIRT INSTALLATION (OPTIONAL)

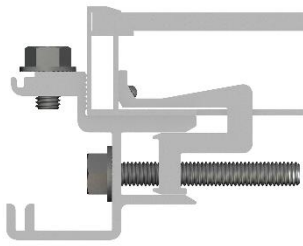
		
<p>Attach either the Skirt Clamp or the Skirt Splice Clamp to the module frame and torque to 13Nm (10 ft-lbs).</p>		

	<p>Attach 2 (two) Skirt Clamps to the edge of each module.</p> <p>Alternatively, 1 (one) Skirt Clamp and 1 (one) Skirt Splice Clamp can be attached to the module edge.</p>
--	---

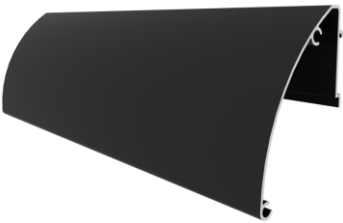
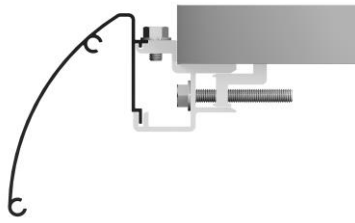
		<p>Insert the Skirt into the Skirt Clamp and torque to 13Nm (10 ft-lbs).</p>
---	---	--

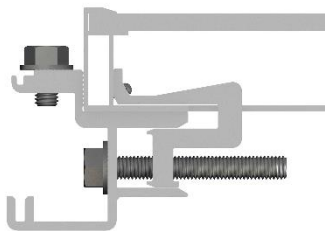
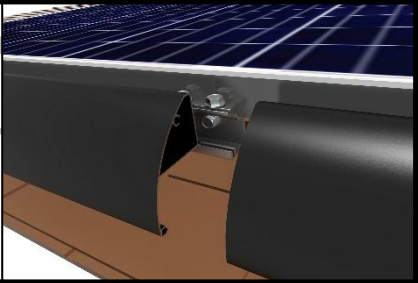
		
<p>Skirt Splice Clamps are to be used where the ends of two Skirt pieces meet along the module edge. There is a minimum of 2 Clamps per Skirt segment.</p>		

SKIRT INSTALLATION (OPTIONAL)

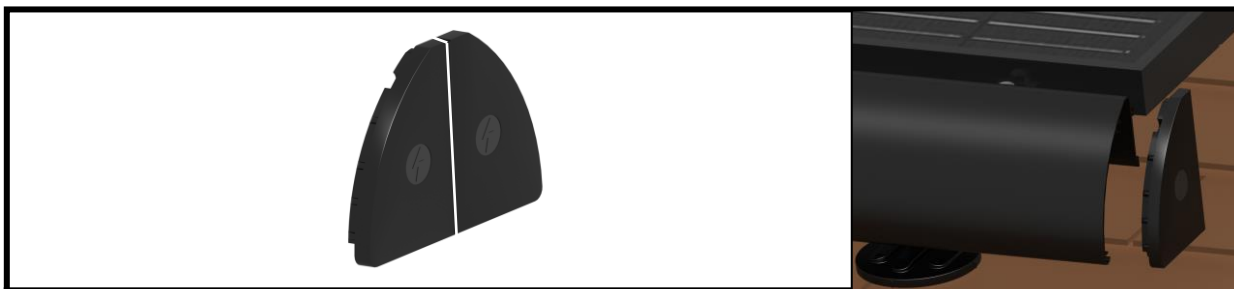

After installing a Leading-Edge Skirt to the module array, cut the Skirt to length as required. Complete the look by installing the End Caps. Separate and insert the End Caps into the ends of the Skirt.

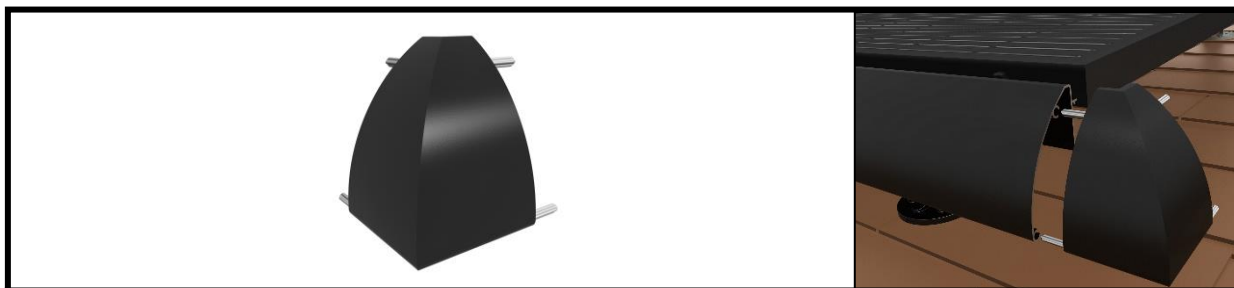

Install the Outer Corners when going around the perimeter of the module array.





Install the Inner Corners, if needed, when going around the perimeter of the module array when a corner module has been removed.

WIRE MANAGEMENT ACCESSORIES



Combine the Conduit Clamp with a NanoPlus to create conduit supports in the desired locations.

<p>SUNMODO Vancouver, WA, USA DATE CODE 01 02 03 04 05 06 07 08 09 10 11 12 2023 2024 2025</p>	<p>Confirms to UL STD-2703 SUNMODO NANORACK SYSTEM System Fire Class Rating: See Installation Instructions for Installation Requirements to Achieve a Specified System Fire Class Rating with this Product. Load Rating: See Installation Instructions.</p>		
---	--	---	--

When requested the UL 2703 Label can be located on the NanoPlus

FAULT CURRENT PATH DIAGRAM

Landscape Configuration

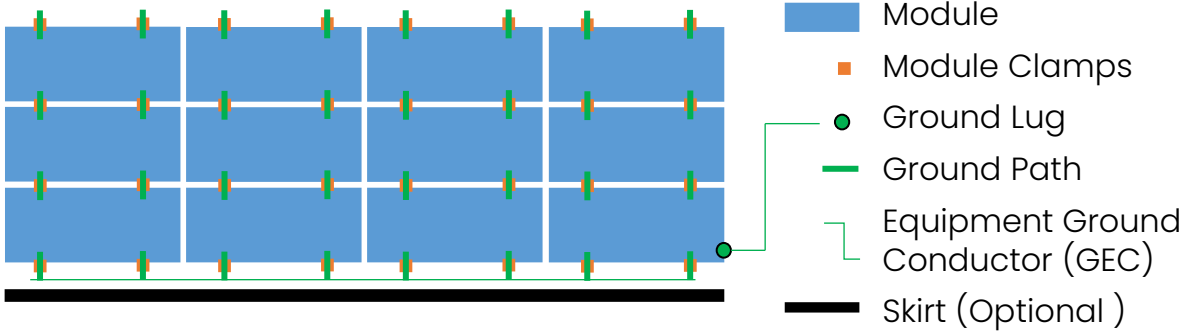

Portrait Configuration

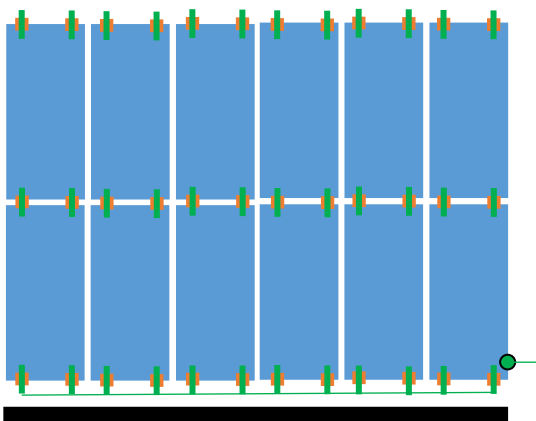

Option 2: East-west bonding can be achieved by installing one Grounding Lug per column and wired in series. Using the M8 Screw attach the Grounding Lug to the module clamp and torque to 10.2 Nm (7.5 ft. lbs.).

Option 3: Alternatively, the picture shows a Grounding Lug mounted on the module frame and a #6 solid copper grounding wire connecting the Ground Lug to the building ground per NEC 690.47.

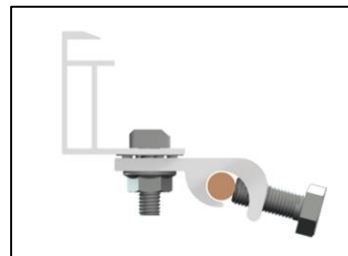

Reference the solar module manufacturer's instructions regarding attaching the Grounding Lug.

The self-bonding system is for use with PV modules that have a maximum series fuse rating of 30A.

CAUTION: Module removal may disrupt the bonding path and could introduce the risk of electric shock. Additional steps may be required to maintain the bonding path. Modules should only be removed by qualified persons in compliance with the instructions in this manual.

Relocate the Grounding Lug to an adjacent module, if necessary, to maintain bonding path of the array.

Option 1: East-west bonding can be achieved by installing the Skirt to the leading edge of the array.

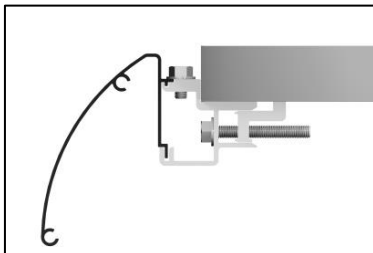

UL 2703 QUALIFIED MODULES

Evaluated PV Modules	
Module manufacturer	Model numbers
Aptos	DNA-108-BF10-xxxW, DNA-108-MF10-xxxW, DNA-120-BF10-xxxW, DNA-120-MF10-xxxW, DNA-120-BF23-xxxW, DNA-120-MF23-xxxW, DNA-144-BF23-xxxW, DNA-144-MF23-xxxW, DNA-120-BF26-xxxW, DNA-120-MF26-xxxW, DNA-144-BF26-xxxW, DNA-144-MF26-xxxW
Astronomy	CHSM6612M-xxx, CHSM6612M/HV-xxx
AXITec Solar	AC-xxxP/60S, AC-xxxMH/120S, AC-xxxMH/120V, AC-xxxMH/144S, AC-xxxMH/144V
Boviet Solar	BVM6610M-xxx, BVM6612M-xxx, BVM6610P-xxx, BVM6612P-xxx
BlueSun Solar	BSMxxxM10-54HPH, BSMxxxM10-54NHB, BSMxxxM10-54NHS, BSMxxxPMB7-46SC, BSMxxxPMB6-60SC, BSMxxxPMB6-70SDC
C-Sun	CSUNxxx-60M, CSUNxxx-60P, CSUNxxx-72M, CSUNxxx-72P
Canadian Solar	CS3N-xxxMS, CS3W-xxxMB-AG, CS3W-xxxP, CS3W-xxxPB-AG, CS6K-xxxM, CS6K-xxxMS, CS6P-xxxM, CS6U-xxxP, CS6V-xxxM, CS6V-xxxP, CS6W-xxxMB, CS6X-xxxP
ET Solar	ET-P672xxxWW
Hansol	HSxxxSE-V01
Hanwha Q Cells	Q.PEAK DUO-L-G4.2 xxxW, Q.PEAK DUO L-G5.2 xxxW, Q.PEAK DUO-G5-BLK xxxW, Q.PEAK DUO L-G6.2 xxxW, Q.PEAK DUO L-G7.3 xxxW, Q.PEAK DUO-G5 xxxW, Q.PRO L-G2 xxxW, Q.PEAK DUO ML-G10 xxxW, Q.PEAK DUO XL-G10 xxxW, Q.PEAK DUO XL-G11 xxxW, Q.PEAK DUO XR-G10 xxxW, Q.PEAK DUO BLK-G6 xxxW, Q.PEAK DUO L-G5.2 xxxW, Q.PEAK DUO L-G5.3 xxxW, Q.PEAK DUO L-G6.2 xxxW, Q.PEAK DUO BLK ML-G9 xxxW, Q.PEAK DUO BLK-G10 xxxW, Q.PEAK DUO BLK ML-G10 xxxW, Q.PEAK DUO BLK ML-G10+ xxxW, Q.PEAK DUO BLK-G10+/AC
Hareon	HR-xxxP-24/Ba
Heliene	60M-320-G1-BLK, 66M-360-HJT-M2+BLK, 72M-xxx, 72M-BLK-xxx, 72P-xxx, 96M-xxx
Hyperion Solar	HY-DH108P8-xxxW-B, HY-DH144P8-xxxW
Hyundai	HiS-MxxxTI, HiS-SxxxTI, HiN-SxxxXG (BK), HiS-SxxxYH (BK)
Itek Energy	ITxxxHE, ITxxxSE
JA Solar	JAM60D00-xxx/BP, JAM72S09-xxx/PR, JAP6 72-xxx/3BB, JAM72D00-xxx/PR, JAM72S09 -xxx/PR
Jinko	JKMxxxM-6R13-B, JKMxxxM-60HL, JKMxxxM-60L, JKMxxx-72L-V, JKMxxx-72HL-V, JKMxxxM-60HBL, JKMxxxM-72HL-V, JKMxxxM-72HL-TV, JKMxxx-7RL3-TV, JKMxxx-60HL4, JKMxxx-60HL4-V, JKMxxx-72HL4, JKMxxx-72HL4-V, JKMxxxM-72HL4-V, JKMxxxM-72HL4-BDVP, JKM430M-72HLM-TV
Kyocera	KDxxxGX-LFB, KUxxx-6MCA, KDxxxGX-LFB2
LG	LGxxxA1C-A6, LGxxxM1C-A6, LGxxxM1K-A6, LGxxxN1C-A6, LGxxxN1C-E6, LGxxxN1C-G4, LGxxxN1C-N5, LGxxxN1K-A6, LGxxxN1K-B6, LGxxxN1K-E6, LGxxxN1K-G4, LGxxxN1K-V5, LGxxxN1T-G4, LGxxxN2T-E6, LGxxxN2W-A5, LGxxxN2W-B3, LGxxxN2W-E6, LGxxxN2W-G4, LGxxxN3K-A6, LGxxxQAC-A6, LGxxxQAK-A6, LGxxxQ1C-A6, LGxxxQ1C-V5, LGxxxQ1K-A6, LGxxxQ1K-V5, LGxxxS1C-G4, LGxxxS2W-G4
LONGi	LR4-60HPB-xxxM, LR4-72HPH-xxxM, LR5-54HABB G2-xxxM, LR5-54HABB V2-xxxM, LR5-54HPB-xxxM, LR5-54HTB-xxxW, LR5-54HABB-xxxW, LR5-72HBD-xxxM, LR6-60PE-BOW-xxxW, LR6-60HPH-BOB-xxxW, LR7-54HGBB-xxxW, LR672HPH-SOW-xxxW
Meyer Burger	MB_B120AyB_XXX, MB_TG120ByB_XXX, MB_W120AyB_XXX
Mission Solar	MSExxxSQ5T, MSExxxSQ8T, MSExxxSQ9J, MSExxxSQ9S, MSExxxSR8T, MSExxxSR9S, MSExxxSX5T, MSExxxSX5R, MSExxxSX6Z, MSExxxSX6W
Mitrex	Mxxx-A1F, Mxxx-B1F, Mxxx-H1H, Mxxx-I1H, Mxxx-L3H
Mitsubishi	PV-MLEXxxHD
Panasonic	EVPVxxxH, EVPVxxxK, EVPVxxxPK, VBHNxxxKA01, VBHNxxxKA03, VBHNxxxKJ01, VBHNxxxSA16, VBHNxxxSA17
Philadelphia Solar	PS-M108(HCBF)-xxxW, PS-M144(HCBF)-xxxW, PS-MNB108(HCBF)xxxW, PS-MNB144(HCBF)xxxW, PS-MNB156(HCBF)xxxW
Phono Solar Tech	PSxxxM-20/U, PSxxxP-24T, PSxxxM1-24/TH, PSxxxM1H-24/TH, PSxxxM1-24/TH
REC Solar	RECxxxNP, RECxxxTP2, RECxxxTP2 BLK2, RECxxxTP2S 72, RECxxxTP2SM 72, RECxxxNP2 BLACK, RECxxxNP3 BLACK, RECxxxAA BLACK, RECxxxTP4 BLACK, RECxxxAA PURE, RECxxxAA PURE-R
RECOM	RCM-xxx-SMS, RCM-xxx-SMD2, RCM-xxx-SMA, RCM-xxx-SMD2, RCM-xxx-6ME, RCM-xxx-6MF
Renesola	JC xxx M-24/Bbs, JC xxx M-24/Bb, JC xxx M-24/Abs, JC xxx S-24/Abs, JC xxx S-24/Bbs
Risen Solar	RSM40-8-xxxM, RSM120-8-xxxM, RSM144-6-xxxM, RSM150-8-xxxM, RSM156-6-xxxM
Sanyo	HIP-xxxBA3, HIT-NxxxA01
SEG	SRP-xxx-6MA, SRP-xxx-6MA-DG, SRP-xxx-6MB, SRP-xxx-6MB-DG, SRP-xxx-6MB-HV, SRP-xxx-6PA, SRP-xxx-6PA-DG, SRP-xxx-6PA-HV, SRP-xxx-6PB, SRP-xxx-6PB-DG, SRP-xxx-6PB-HV, SEG-xxx-BMA, SEG-xxx-BMA-HV, SEG-xxx-BMB-HV, SEG-6MA-xxxBB, SEG-6MA-xxxBW, SEG-6MA-xxxWB, SEG-6MA-xxxWW, SEG-6MB-xxxBB, SEG-6MB-xxxBW, SEG-6MB-xxxWB, SEG-6MB-xxxWW, SEG-BMA-xxxBB, SEG-BMA-xxxBW, SEG-BMA-xxxWB, SEG-BMA-xxxWW, SRP-xxx-BMA, SRP-xxx-BMA-HV, SRP-xxx-BMB, SRP-xxx-BMB-HV, SRP-xxx-BMZ, SRP-xxx-BMZ-HV, SRP-xxx-BPA, SRP-xxx-BPA-HV, SEG-xxx-BMD-HV
Silfab	SLAxxxM, SLGxxxM, SLAxxxMCH, SLAxxxMWT, SLA-M xxx, SLA-X-xxx, SLG-X-xxx, SIL-xxx NL/BL/HC+/HL/NT/ML/BK/NX/NU
Solaria	PowerX-xxxR, PowerXT-xxxR-AC, PowerXT-xxxR-BX, PowerXT-xxxR-PX, PowerXT-xxxR-BD, PowerXT-xxxR-PD, PowerXT-xxxR-PD
Solar 4 America	S4Axxx-72MH5, S4Axxx-72MH5BB, S4Axxx-108MH10, S4Axxx-144MH10, S4A-USxxxB
SolarWorld (V2.5 frame)	Sunmodule SW series: SW xxx mono and poly, SW xxx mono, SW xxx poly, Sunmodule Plus series: xxxW mono, Sunmodule Protect xxxW mono, Sunmodule SW xxx poly / Pro-Series
SolarWorld (33mm frame)	Sunmodule Pro-Series: xxxW poly, xxxW XL mono, Sunmodule Plus: xxxW mono
Stion	STO-xxxA
SunEdison	FxxxSMRD, FxxxSMRC, RxxxSMRC
SunPower	SPR-xxxE-WHT-D, SPR-Axxx, SPR-E19-xxx, SPR-E19-xxx-COM, SPR-E19-xxx, SPR-E20-xxx, SPR-E20-xxx, SPR-E20-xxx-COM, SPR-E20-xxx-D-AC, SPR-P17-xxx-COM, SPR-
Maxeon Technology	P5-xxx-UPP, SPR-X20-xxx-BLK, SPR-X20-xxx-BLK-B-AC, SPR-X20-xxx-C-AC, SPR-X21-xxx-BLK, SPR-X21-xxx-BLK-D-AC, SPR-X21-xxx, SPR-X21-xxx-COM, SPR-X21-xxx-D-AC, SPR-X21-xxx-BLK, SPR-X21-xxx-BLK-D-AC, SPR-X21-xxx-BLK, SPR-X21-xxx-COM, SPR-X22-xxx, SPR-X22-xxx-COM, SPR-X22-xxx-D-AC, SPR-X22-xxx-D-AC, SPR-MAX3-xxx-BLK-R, SPR-MAX6-xxx-BLK-E3-AC, SPR-MAX6-xxx-BLK-E4-AC
Trina	TSM-xxx PC/PA05, TSM-DE15M(II), TSM-DEG15MC.20(II), TSM-DE15H(II), TSM-DEG15HC.20(II), TSM-DE15V(II), TSM-DEG15VC.20(II), TSM-DEG18MC.20(II) TSM-DE19, TSM-DEG19C.20, TSM-DE21, TSM-DEG21C.20
URE	FAMxxxE7G-BB, FAMxxxE8G-BB, FBMxxxMFG-BB, F6MxxxE7G-BB, FBMxxxMFG-BB
Yingli	YLxxxP-29b
ZnShine	ZXM6-NHLLD144 Series, ZXM6-NH120 Series, ZXM7-SHLLD144 Series, ZXM7-SH144 Series

ADDENDUM: METAL ROOF ATTACHMENT



Replace the NanoPlus roof attachments with the MRB mounts and complete the Groundwork as previously shown in this document. When installation the MRB mounts to the metal roof it is important to attach first module in the array on the peak of the metal roof profile. Using the slot in the L-Foot level the remaining modules in the array as the modules are installed..

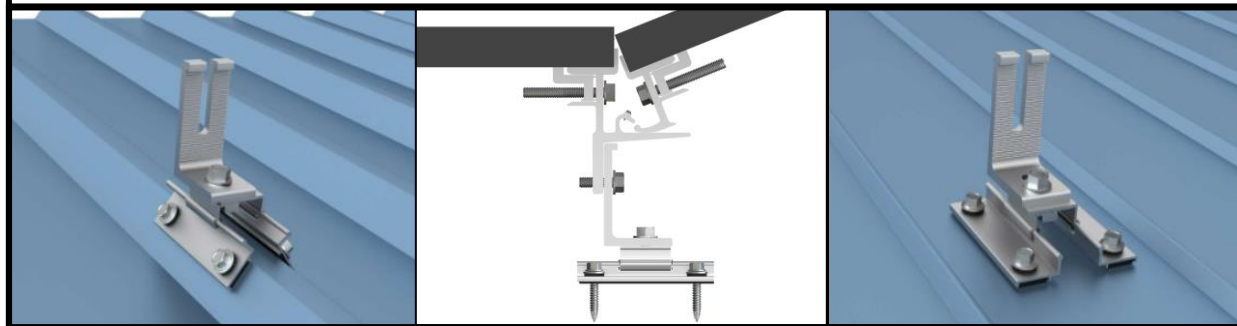

ADDENDUM: METAL ROOF ATTACHMENT

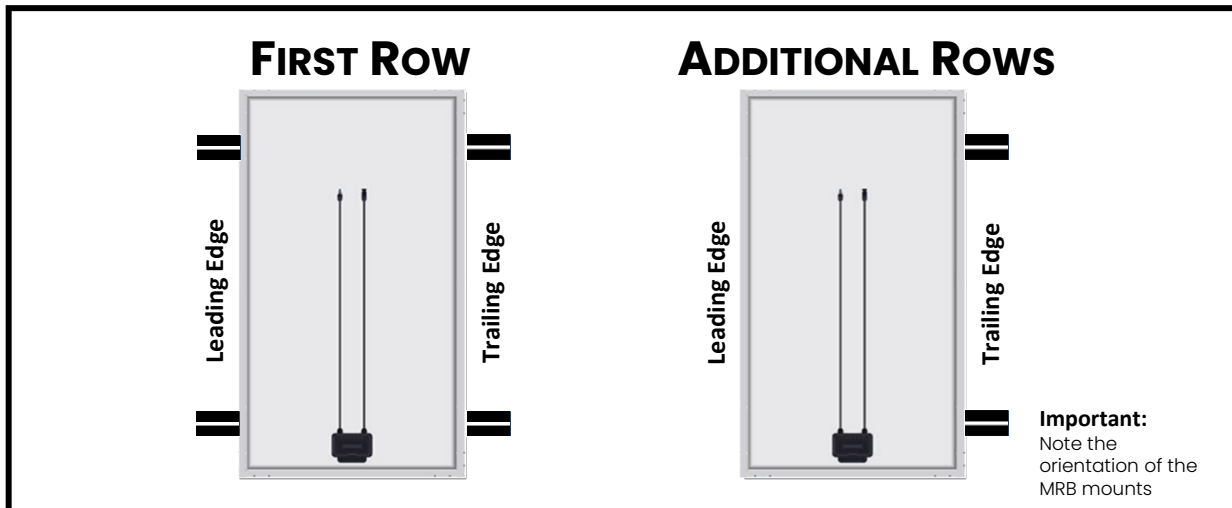

Replace the NanoPlus roof attachments with the MRB mounts and complete the Groundwork as previously shown in this document. When installation the MRB mounts to the metal roof it is important to attach first module in the array on the peak of the metal roof profile.

FIRST ROW & FIRST MODULE ATTACHMENT

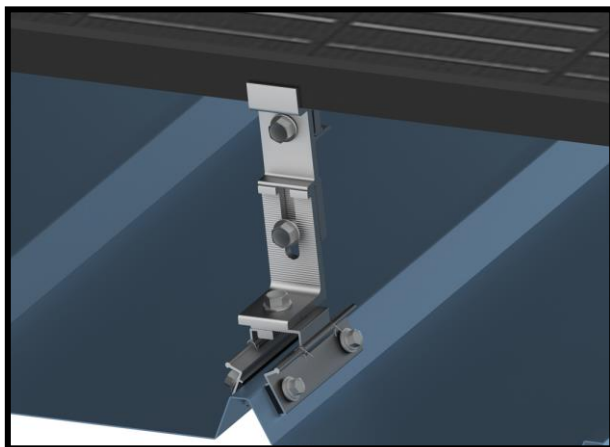

Attach one row of MRB mounts of the first module on the peak of the metal roof profile.

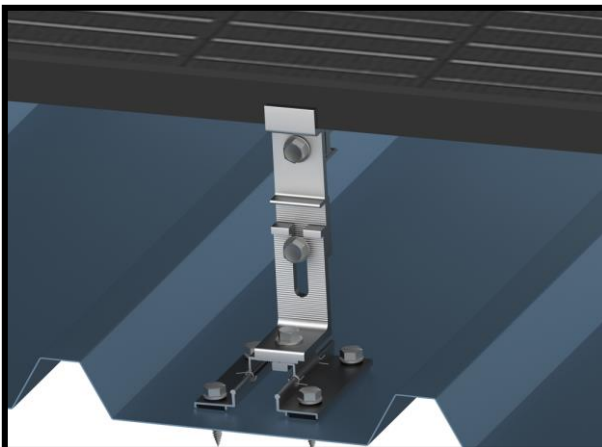

Note the L-Foot height adjustment required to level the module.

ADDENDUM: STAGGERED MODULES



Using your engineered design, determine the solar panel array placement on the roof.

See pages 12 - 15 for complete roof attachment instructions.

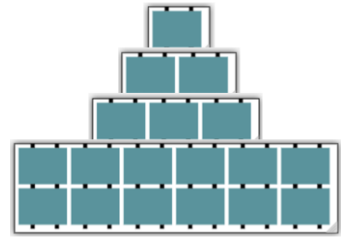

Important:
Install Module Brackets
 $1/4$ the distance of the
length of the module

FIRST ROW

ADDITIONAL ROWS

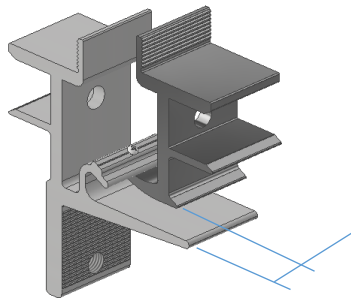
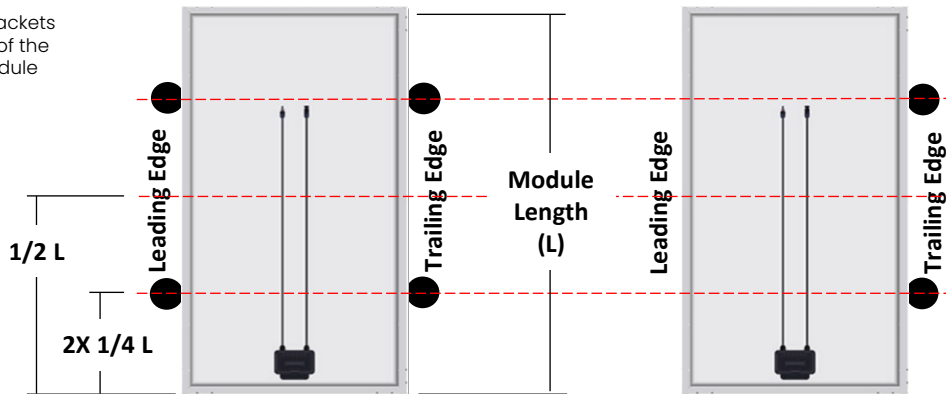

$5/8$ " maximum offset to ensure
Bonding Pin engagement
between the module brackets.